

GROUP 23

CONTINUOUSLY VARIABLE TRANSMISSION (CVT)

CONTENTS

CVT	23-2	ELECTRONIC CONTROL SYSTEM.....	23-21
GENERAL INFORMATION.....	23-2	CONTROL DESCRIPTION.....	23-21
PRINCIPLE OF IMPROVEMENTS IN FUEL ECONOMY AND PERFORMANCE WITH CVT	23-4	SHIFT CONTROL.....	23-22
DESCRIPTION OF STRUCTURE AND OPERATION	23-5	LINE PRESSURE CONTROL.....	23-25
SECTIONAL VIEW.....	23-5	DIRECT CONTROL (DAMPER CLUTCH CONTROL)	23-26
TORQUE CONVERTER.....	23-6	CONTROL BETWEEN N (P) AND D (R)...	23-26
OIL PUMP.....	23-6	CONTROLLER AREA NETWORK (CAN) COMMUNICATION.....	23-26
FORWARD/REVERSE SWITCHING PART	23-6	SELF-DIAGNOSIS FUNCTION.....	23-26
FINAL DRIVE AND DIFFERENTIAL.....	23-7	TRANSMISSION CONTROL.....	23-27
PULLEY AND STEEL BELT.....	23-8	GENERAL INFORMATION.....	23-27
CVT FLUID COOLER.....	23-9	SELECTOR LEVER ASSEMBLY.....	23-29
POWER FLOW.....	23-10	CVT ERRONEOUS OPERATION PREVENTION MECHANISMS.....	23-29
OIL PRESSURE CONTROL SYSTEM.....	23-13	SHIFT LOCK MECHANISM.....	23-29
CONTROL DESCRIPTION.....	23-13	KEY LOCK MECHANISM.....	23-31
SHIFT MECHANISM.....	23-15	PADDLE SHIFT.....	23-31

CVT

GENERAL INFORMATION

M2231000100239

The CVT combines "torque converter" and "continuously variable transmission mechanism by steel belt & pulley" to achieve "high driving performance" and "better fuel economy." Depending on the driving conditions, the comfortable gear ratio is automatically and continuously selected from low to overdrive, ensuring driver-intended smooth driving without shift shocks due to acceleration pedal operation.

SPECIFICATIONS

Transmission model		W1CJA
Torque converter	Model	3-element, 1-stage, 2-phase
	Stall torque ratio	1.83
	Lock-up	Present
Transmission type		Forward automatic CVT (steel belt-driven), reverse 1 speed
Gear ratio	Forward	2.349 – 0.394
	Reverse	1.750
Shift position		P-R-N-D+6-speed sport mode (with the paddle shift)
Final reduction gear ratio		6.120
Control type		Electronically-controlled
Function	Shift control	Present
	Line pressure control	Present
	Select control	Present
	Lock-up control	Present
	Self-diagnosis function	Present
	Fail-safe function	Present
Number of speedometer gears (drive/driven)		–(detected by the ABS sensor rotor)
Oil pump	Model	Vane-type pump
	Drive type	Driven by the engine, sprocket, and chain
CVT fluid	Brand name	DIA QUEEN CVTF-J1
	Capacity (L)	Approximately 7.8

SYSTEM CONFIGURATION

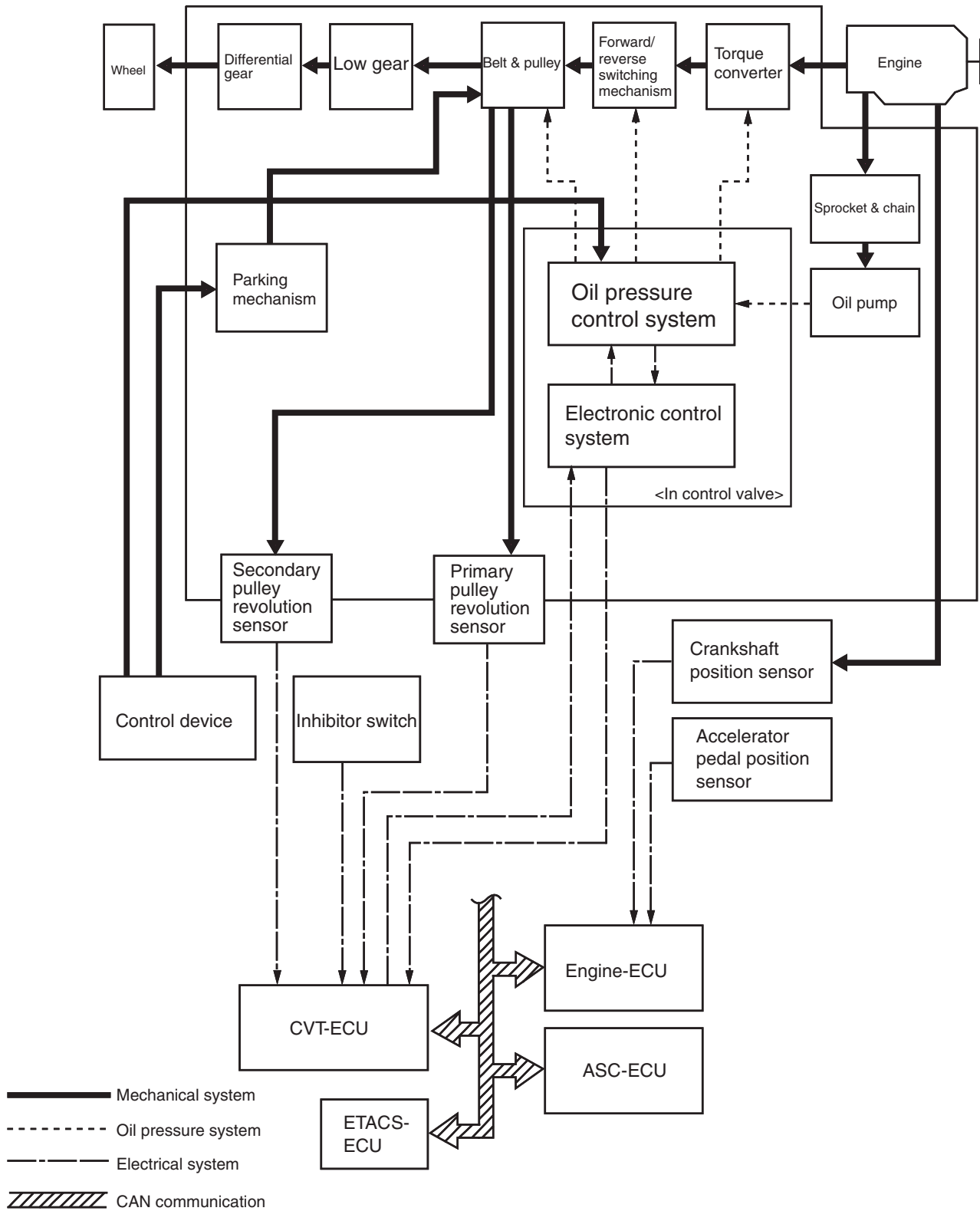

OVERVIEW

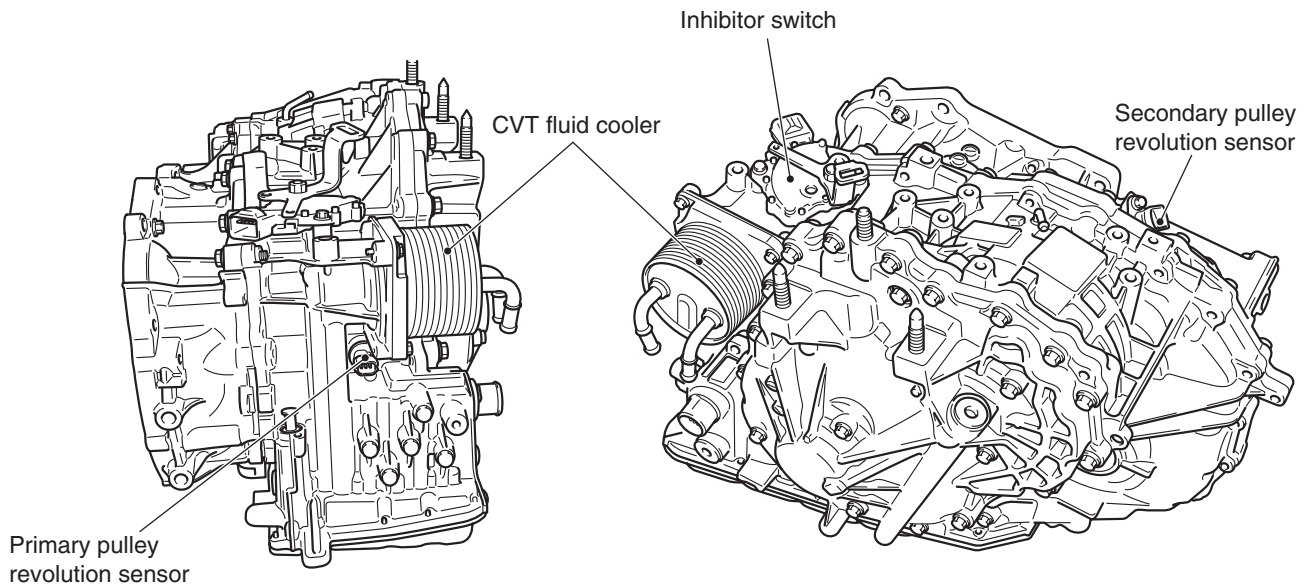

AC507426AB

PRINCIPLE OF IMPROVEMENTS IN FUEL ECONOMY AND PERFORMANCE WITH CVT

M2231001000053

The general concept of CVT is described as follows:

PRINCIPLE OF IMPROVEMENTS IN FUEL ECONOMY

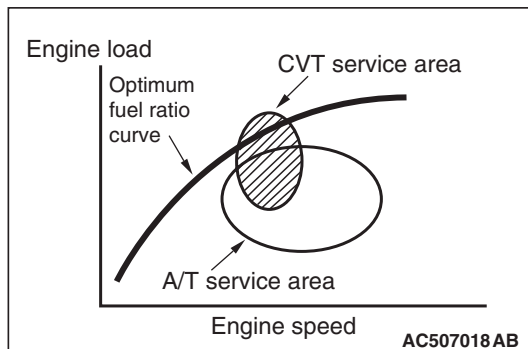

CVT can continuously vary the gear ratio, so the vehicle can be driven in the high engine fuel efficiency range all the time, resulting in excellent fuel economy.

PRINCIPLE OF IMPROVEMENTS IN POWER PERFORMANCE

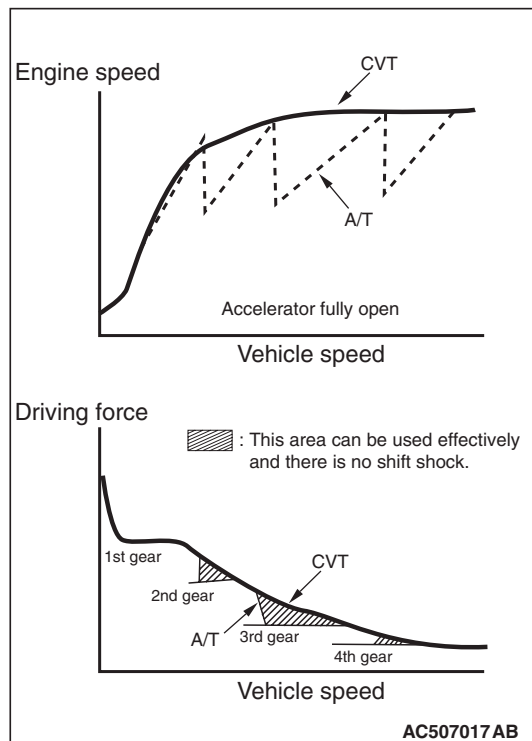

The figure shows the maximum driving force diagram representing the power performance. The comparison with AT shows that when the throttle is fully open, AT causes a step change in driving force due to a step shift, but CVT changes driving force

smoothly because it can accelerate with the engine kept in the high output range. Therefore, CVT provides more smooth and shockless driving without driving loss as much as the shaded area in the figure shows.

DESCRIPTION OF STRUCTURE AND OPERATION

SECTIONAL VIEW

M2231000400036

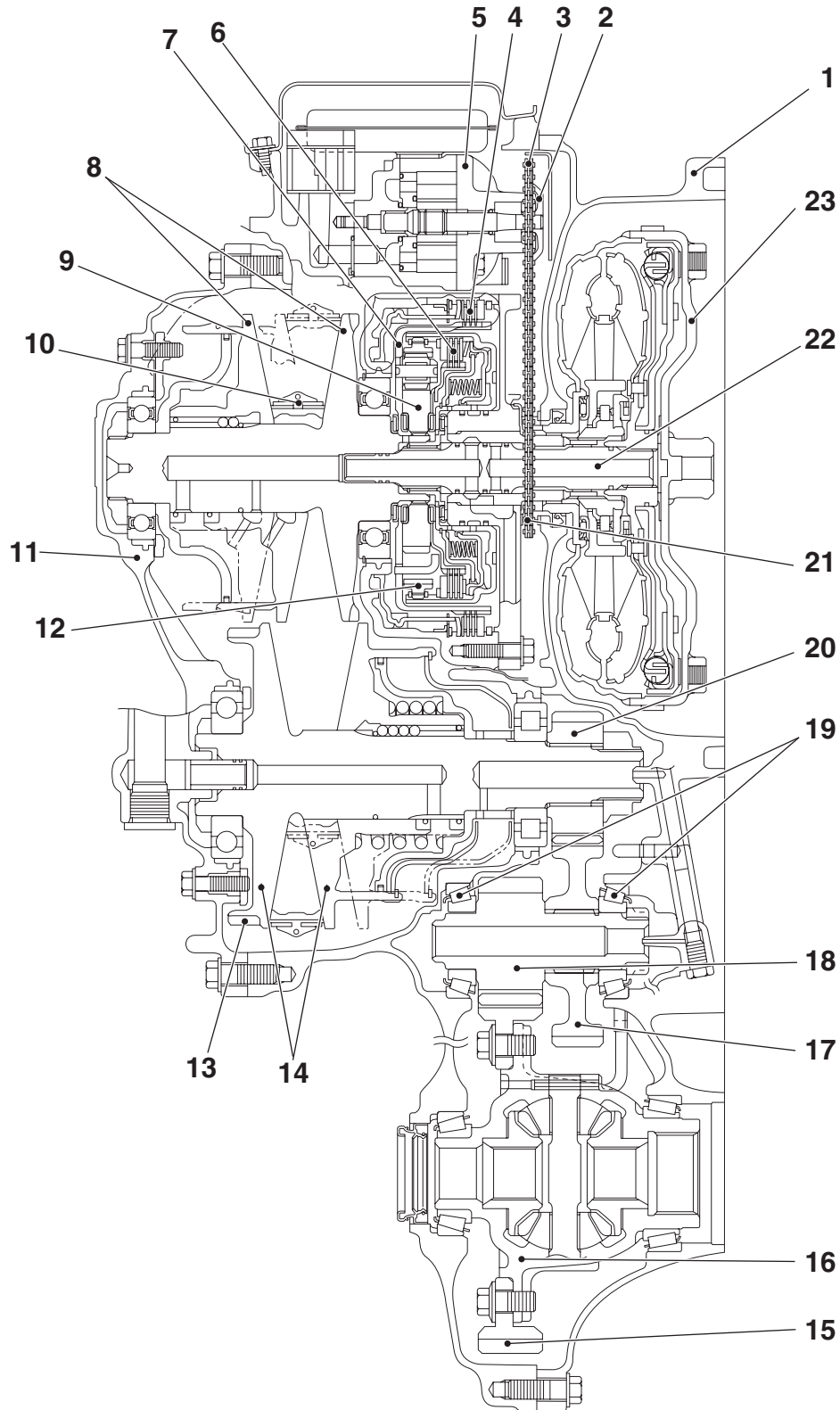

1. Converter housing
2. Driven sprocket
3. Chain
4. Reverse brake
5. Oil pump
6. Forward clutch
7. Planet carrier
8. Primary pulley
9. Sun gear
10. Steel belt
11. Side cover
12. Internal gear
13. Parking gear
14. Secondary pulley
15. Final gear
16. Differential case
17. Idler gear
18. Reduction gear
19. Taper roller bearing
20. Output gear
21. Drive sprocket
22. Input shaft
23. Torque converter

TORQUE CONVERTER

M2231000200032

The torque converter with the "3-element, 1-stage, 2-phase" lock-up mechanism has been adopted as vehicles with AT.

OIL PUMP

M2231000500033

The vane-type oil pump driven by the engine via the oil pump drive chain has been adopted to increase efficiency of the pump discharge amount at a low engine speed and optimise the pump discharge amount at a high engine speed. The oil discharged from the oil pump flows to the control valve, and is used as operating fluid for the primary and secondary pulleys, operating fluid for the clutch, and lubricant for each part.

FORWARD/REVERSE SWITCHING PART

M2231000600030

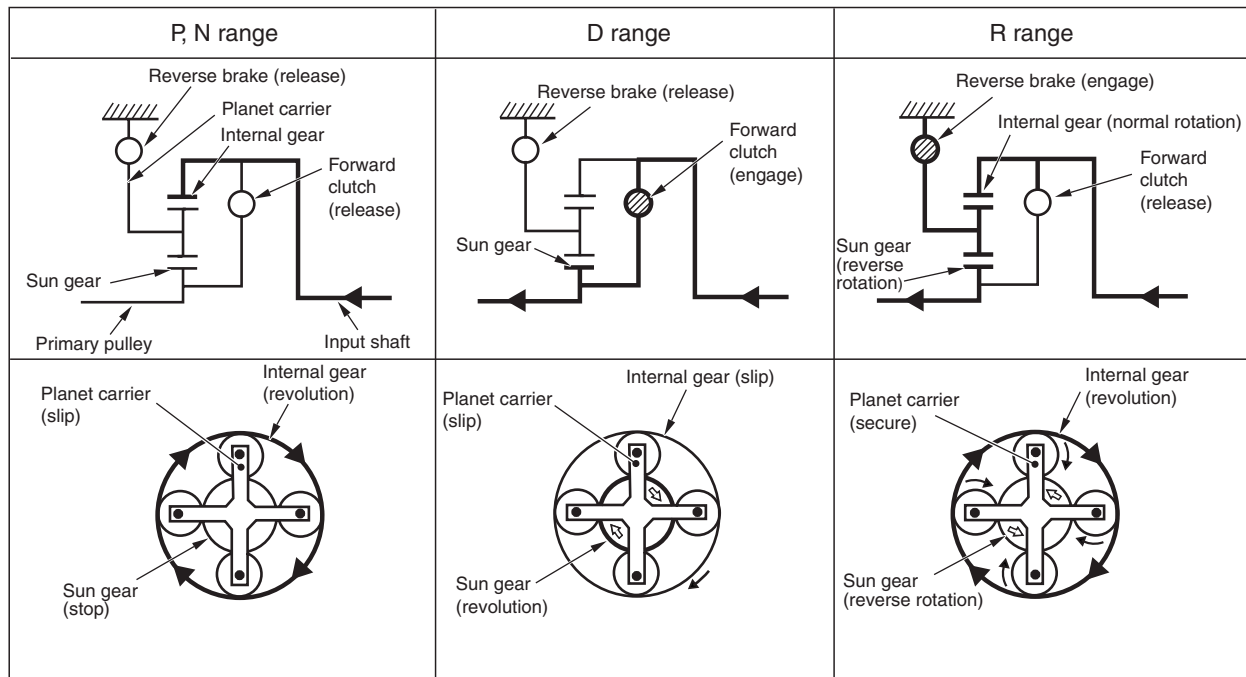

AC504691AB

- The planetary gear type forward/reverse switching mechanism has been installed between the torque converter and primary pulley.
- The power is input from the torque converter via the input shaft and hydraulically activates the wet multi-disc device to switch between forward and reverse gears.

FINAL DRIVE AND DIFFERENTIAL

M2231000700037

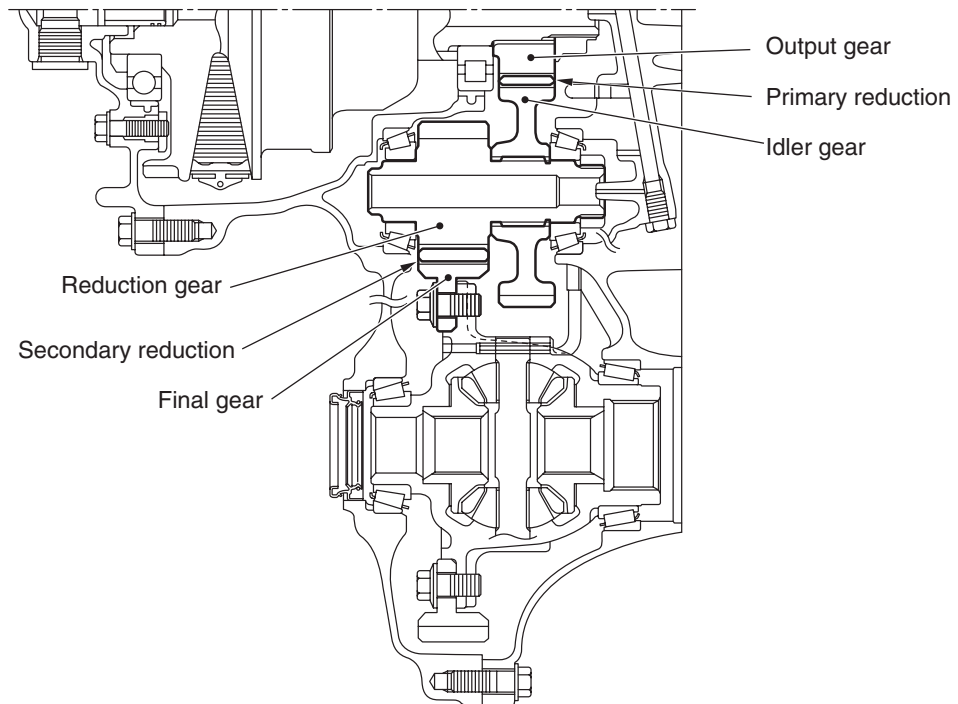

AC506402 AB

- The reduction gear is a 2-stage composition, the primary reduction (a pair of the output gear and idler gear) and secondary reduction (a pair of the reduction gear and final gear). All the gears are helical gears.
- The fluid (Mitsubishi genuine Dia-Queen CVT Fluid-J1) which lubricates the entire transmission is also used as lubricant.

PULLEY AND STEEL BELT

M2231000800034

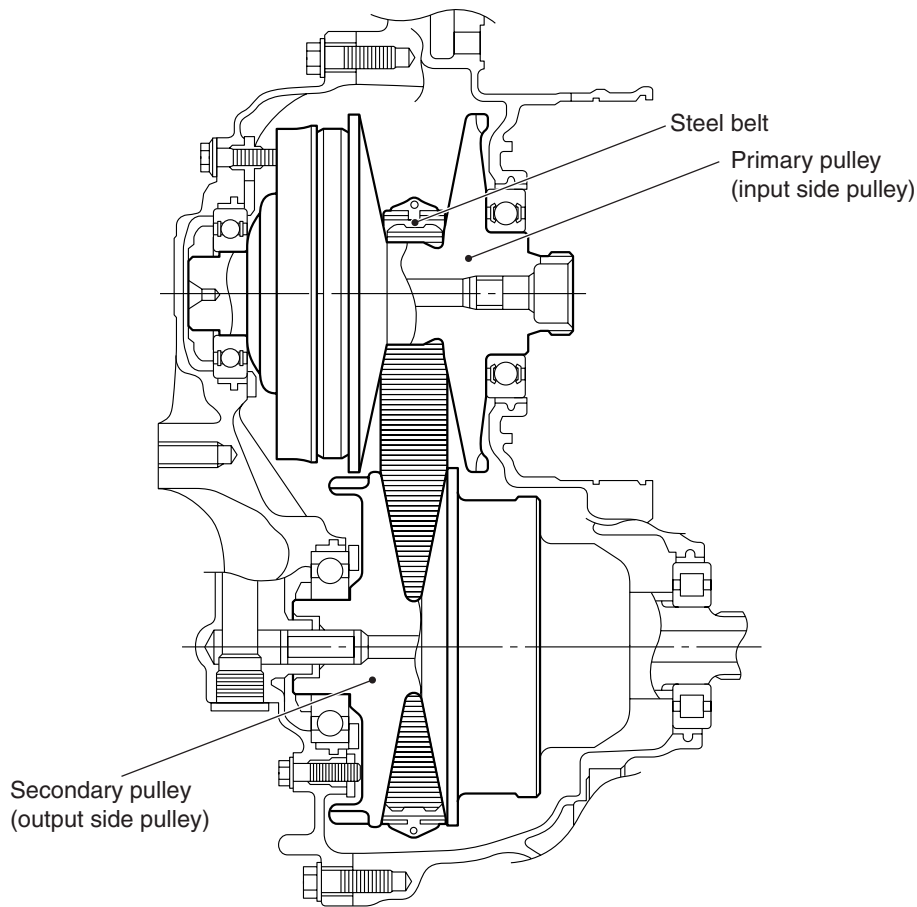

AC504739AC

This unit is comprised of a pair of pulleys of which groove width can be changed freely in the axial direction, and a steel belt made of a continuous series of steel elements guided by multilayer steel rings on the both sides. This groove width is hydraulically controlled by the primary and secondary pulleys, varying continuously from the low status (gear ratio: 2.349) to the overdrive status (gear ratio: 0.394) depending on the winding radius of the steel belt on the pulley.

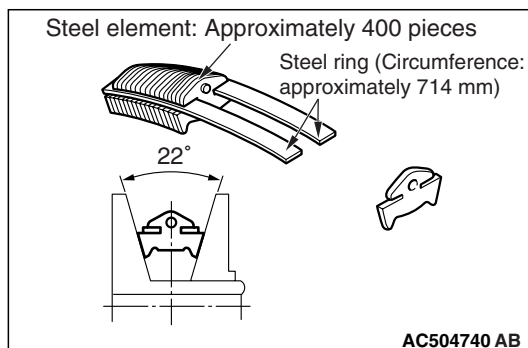
STEEL BELT

AC504740 AB

This is composed of approximately 400 steel elements and two 12-layer steel rings. The steel belt has the following features. Other belts such as a rubber belt transfer driving force by their pulling effect, on the other hand, the steel belt transfers driving force by compression effect of the steel elements. The steel elements require a friction force with the pulley slope to transfer driving force. The mechanism is as follows:

The secondary pulley hydraulically activates to pinch the elements. → The elements are pressed outwards to expand. → The steel rings hold out against the force. → Tension is generated at the steel rings. → The elements on the primary pulley side are pinched between the pulleys. → Friction force is generated between the steel belt and pulley. This means that the steel elements which transfer the driving force by compression and the steel rings which maintain the required friction force share the roles. Then, the tension of the steel rings is distributed over the entire unit with little stress variation, resulting in the excellent durability.

PULLEY

Low status: Gear ratio = $r2/r1$

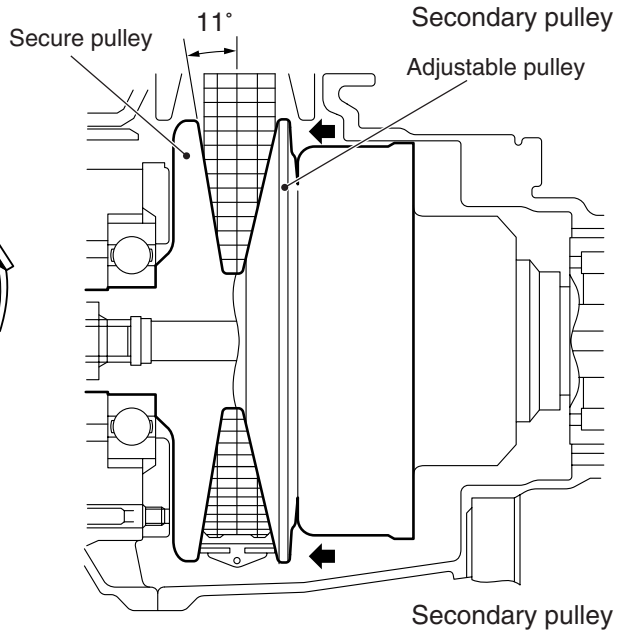
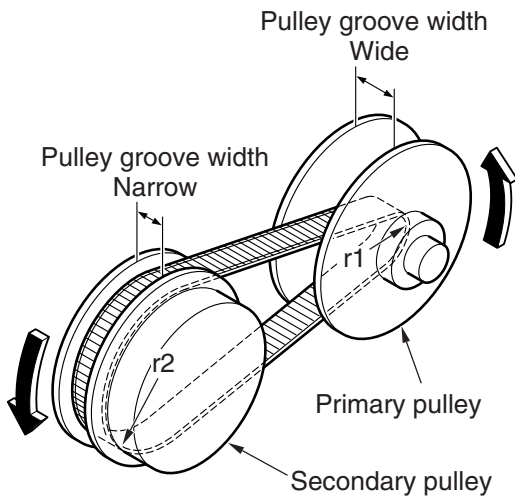

Overdrive status: Gear ratio = $r2/r1$

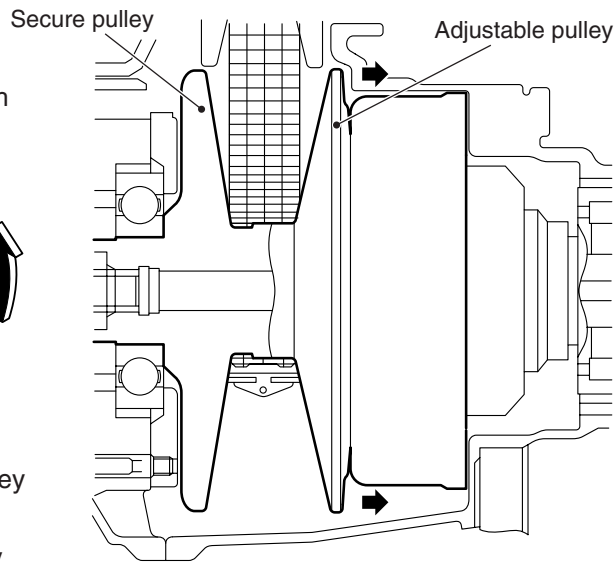
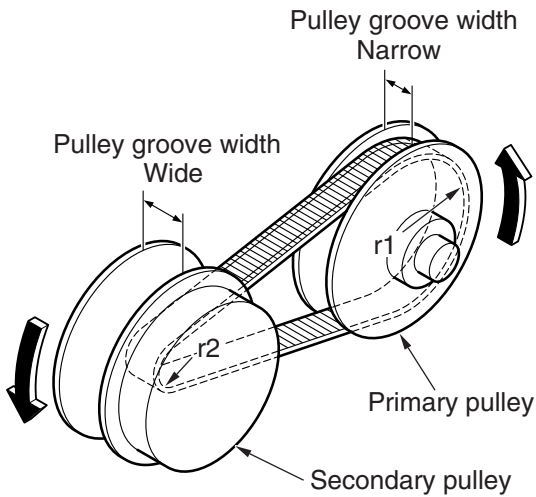

The primary and secondary pulleys are both comprised of the fixed pulley with 11-degree slope and movable pulley. Each has a hydraulic chamber (the primary or secondary chamber) behind the movable pulley. The movable pulley can slide along the axis with a ball spline to change the groove width of the pulley. The groove width of the pulley is controlled by changing the operating pressure at the primary and secondary pulleys using the engine load (accelerator angle), primary pulley speed, and secondary pulley speed (vehicle speed) as input signals.

CVT FLUID COOLER

AC504741AB

M223100900042

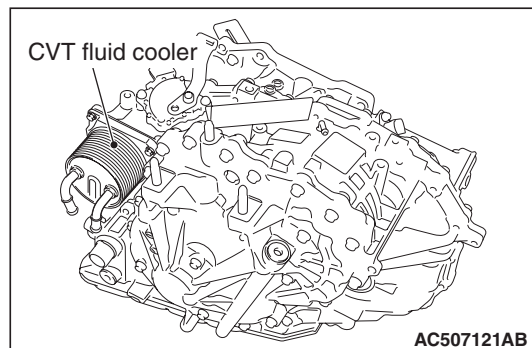

AC507121AB

The water-cooled CVT fluid cooler has been adopted. The CVT fluid cooler has been installed directly to the front of the transmission to shorten the oil passage.

CVT FLUID FILTER

The CVT fluid filter integrated in the transmission assembly has been adopted. Any impurity in the CVT fluid has been removed to increase operational reliability of the automatic transmission.

POWER FLOW

M2231001100038

P RANGE

- The driving force from the engine is not transferred to the primary pulley because the forward clutch and reverse brake are released.
- The torque from the tyres is not transferred to the components upstream of the secondary pulley because the parking gear is fixed.

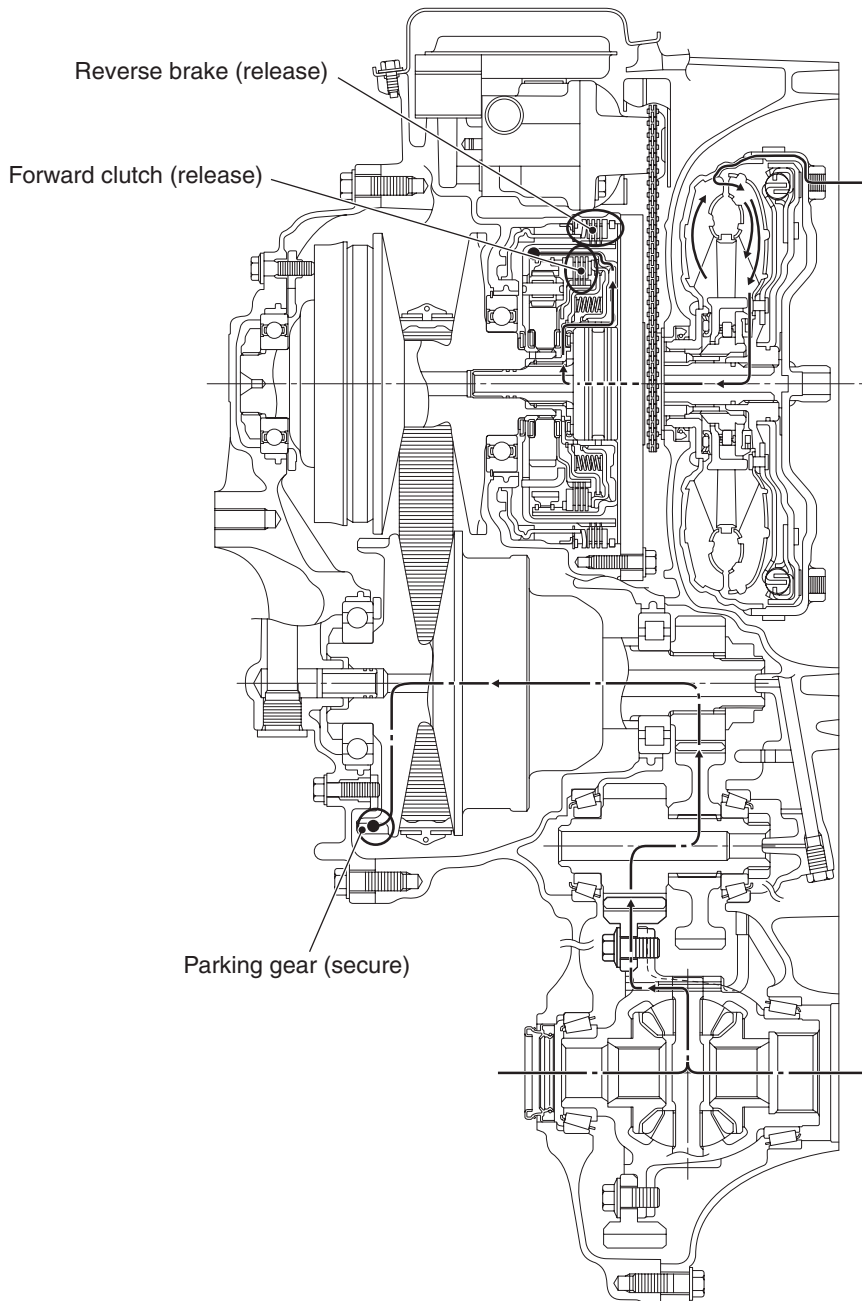

AC507023 AB

R RANGE

- The driving force from the engine rotates the sun gear in the reverse direction because the reverse brake is engaged and the planet carrier is fixed.
- For this reason, the primary pulley rotates in the reverse direction, thus the driving force is output in the reversed state.

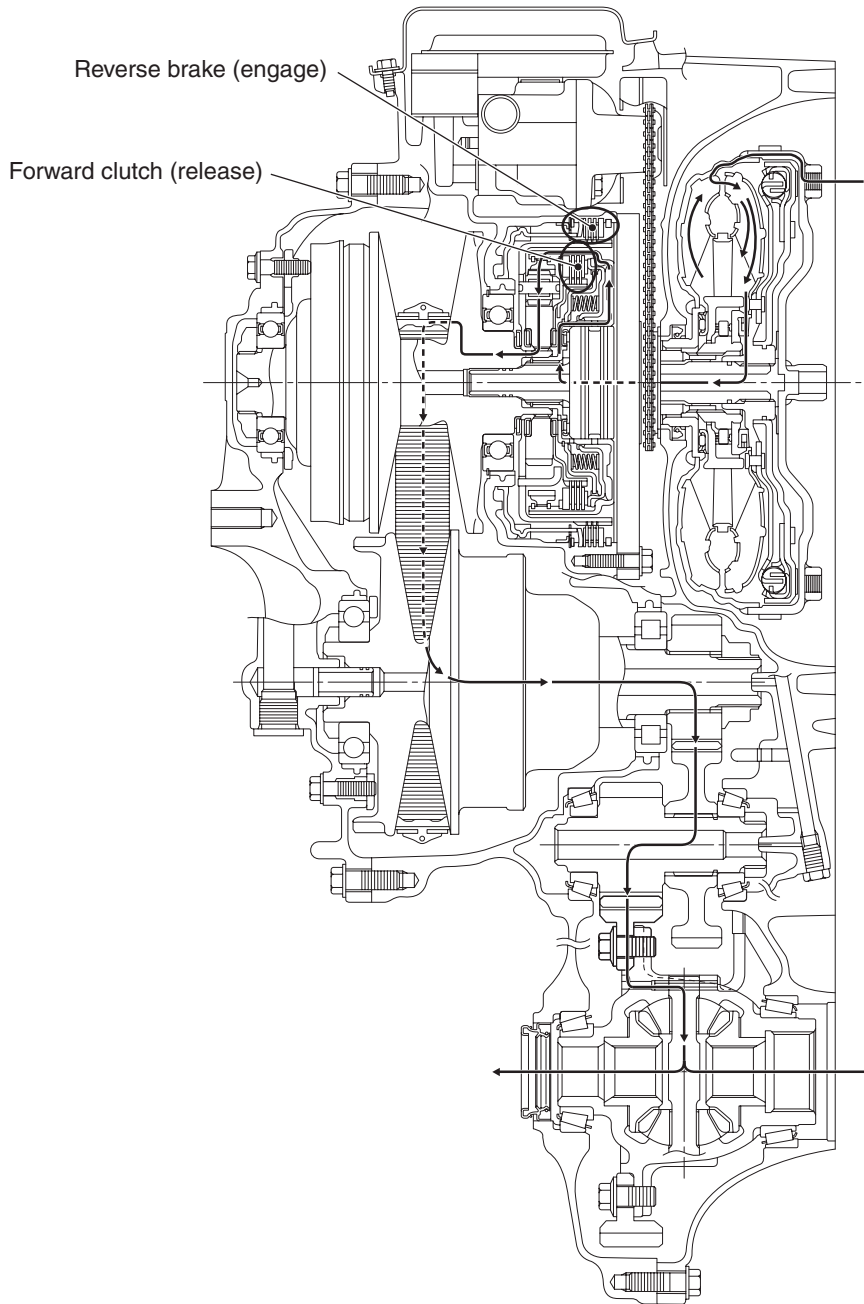

AC507026 AB

N RANGE

- The driving force from the engine is not transferred to the primary pulley because the forward clutch and reverse brake are released.
- The torque from the tyres is not transferred because the forward clutch and reverse brake are released, thus the planet carrier rotates independently.

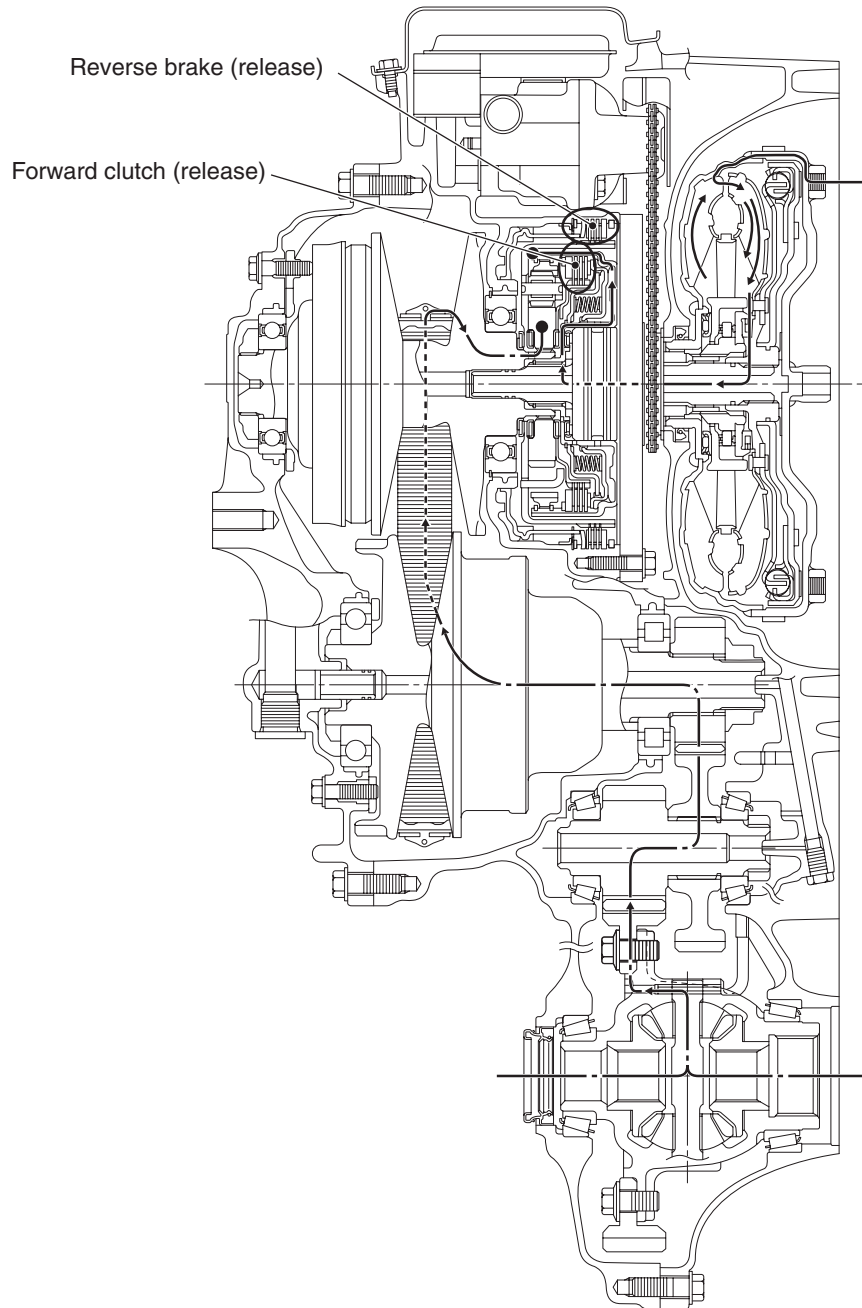

AC507025AB

D RANGE

- The driving force from the engine rotates the sun gear in the normal direction via the forward clutch because the forward clutch is engaged.
- For this reason, the primary pulley rotates in the normal direction, thus the driving force is output in the normal state.

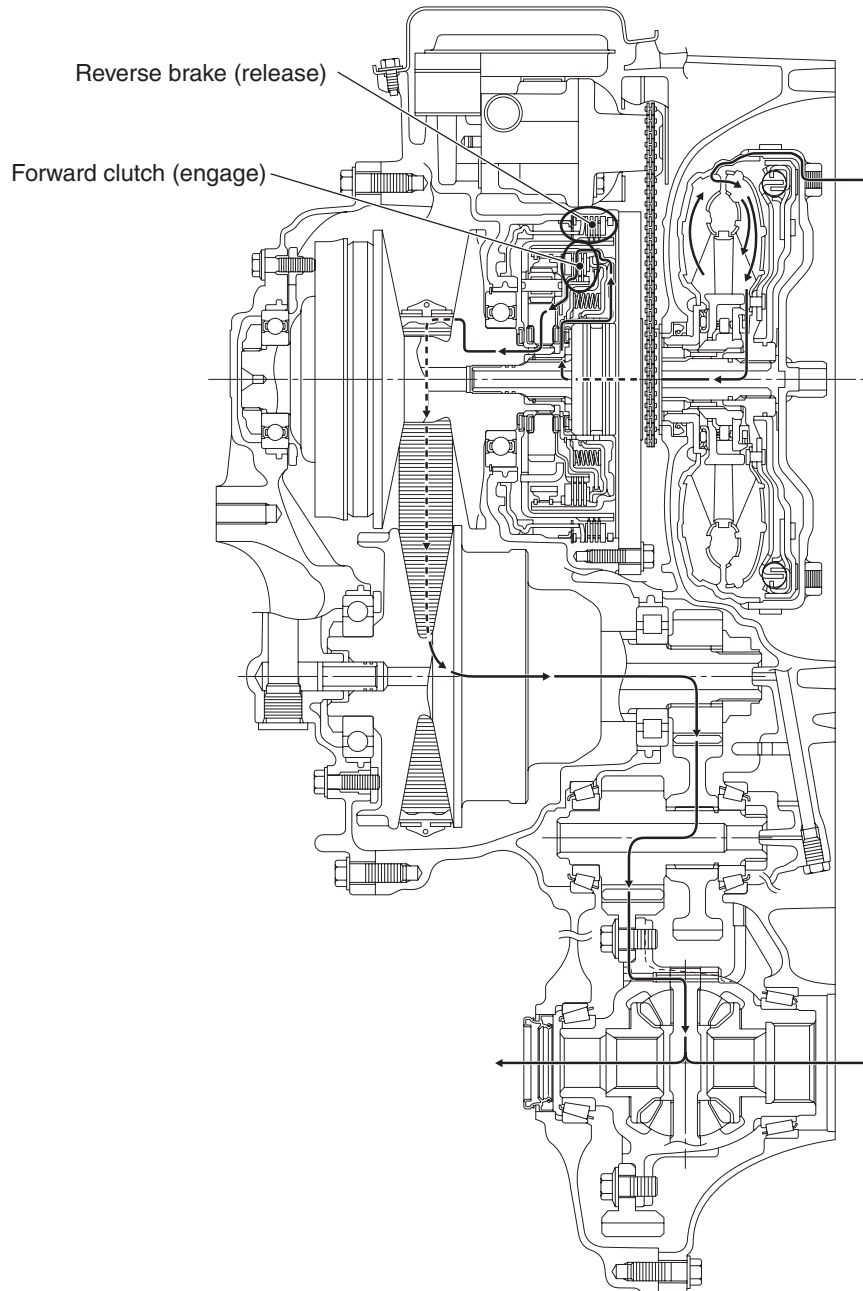

AC507024 AB

OIL PRESSURE CONTROL SYSTEM

CONTROL DESCRIPTION

M2231005000088

HYDRAULIC CONTROL

The hydraulic control mechanism is comprised of the vane-type oil pump driven by the engine via the oil pump drive chain, the hydraulic control valve which controls the line pressure and shift change, and the input signal system.

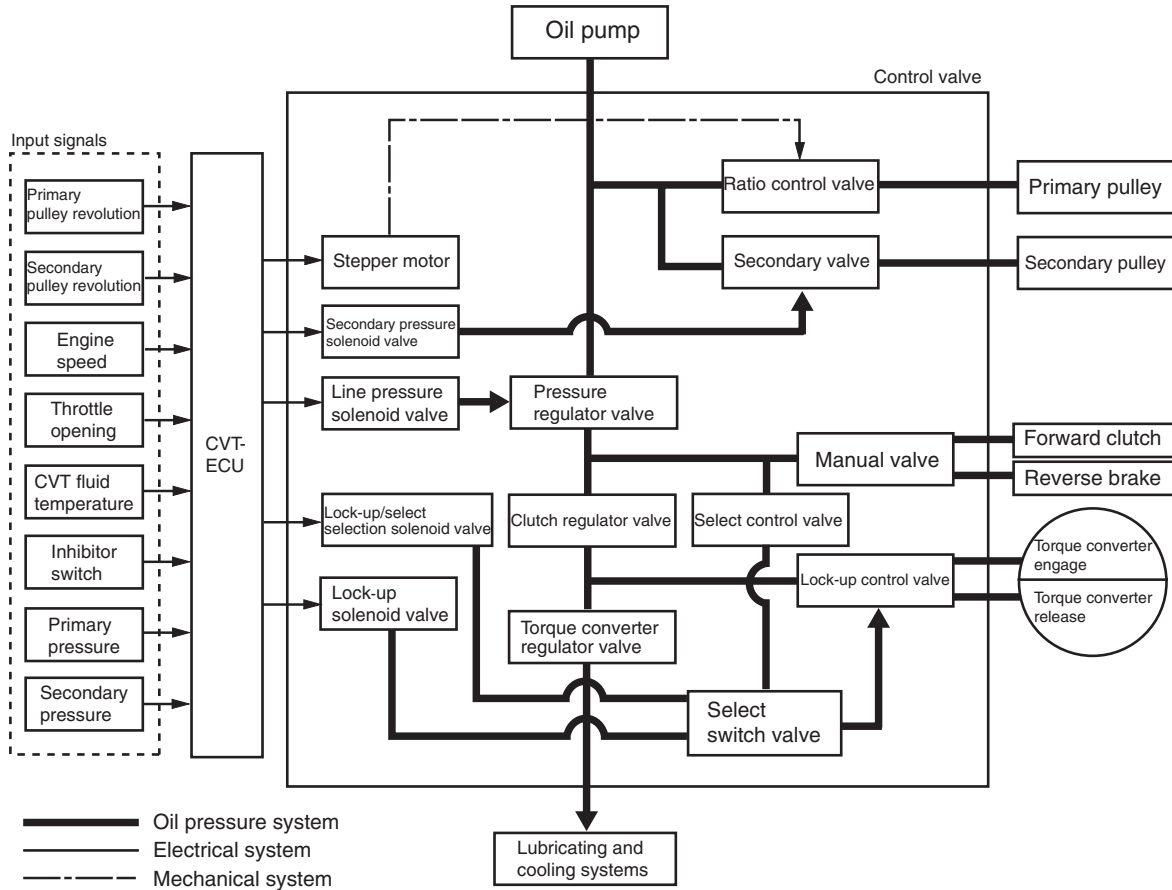

AC504662 AB

GENERAL INFORMATION REGARDING THE MAIN COMPONENTS

Component	Function
Manual valve	Distributes the clutch operating pressure to each circuit, depending on each shift position.
Torque converter regulator valve	Regulates the supply pressure to the torque converter to the optimal pressure for the driving conditions.
Clutch regulator valve	Regulates the clutch operating pressure depending on the driving conditions.
Pressure regulator valve	Regulates the discharge pressure from the oil pump to the optimal pressure (line pressure) for the driving conditions.
Ratio control valve	Controls in/out flow of the line pressure to/from the primary pulley depending on the stroke difference between the stepper motor and primary pulley.
Lock-up/select switching solenoid valve	Controls switching of lock-up solenoid valve control pressure between when lock-up engagement/disengagement is performed and when forward/reverse clutch (forward clutch and reverse brake) engagement/disengagement is performed.
Select switch valve	
Line pressure solenoid valve	Controls the pressure regulator valve.
Lock-up solenoid valve	Controls the lock-up control valve.
Lock-up/select switching solenoid valve	Controls the select switch valve.
Stepper motor	Controls the pulley ratio.

Secondary valve	Reduces the line pressure to regulate the secondary pressure.
Select control valve	Engages when select. Regulates the forward clutch pressure and reverse brake pressure.
Lock-up control valve	Regulates the engagement pressure and disengagement pressure of the torque converter.
Secondary pressure solenoid valve	Controls in/out flow of the line pressure to/from the secondary pulley depending on the driving conditions.

SHIFT MECHANISM

M2231001200035

SHIFTING FROM LOW TO HIGH

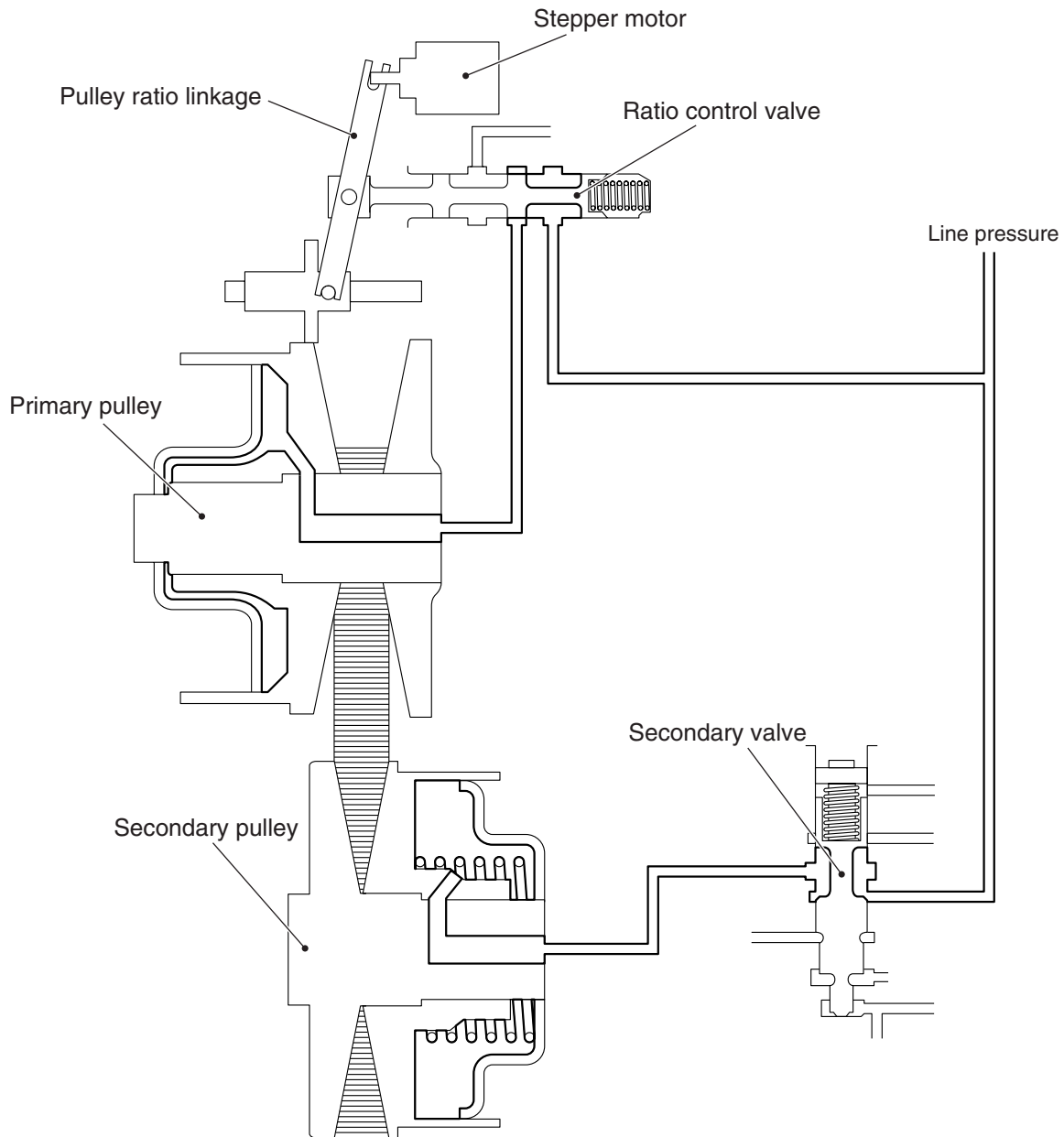

- No line pressure is applied to the primary pulley because the line pressure circuit is closed by the

ratio control valve.

- The line pressure is applied to the secondary pulley because the secondary valve has moved downwards.

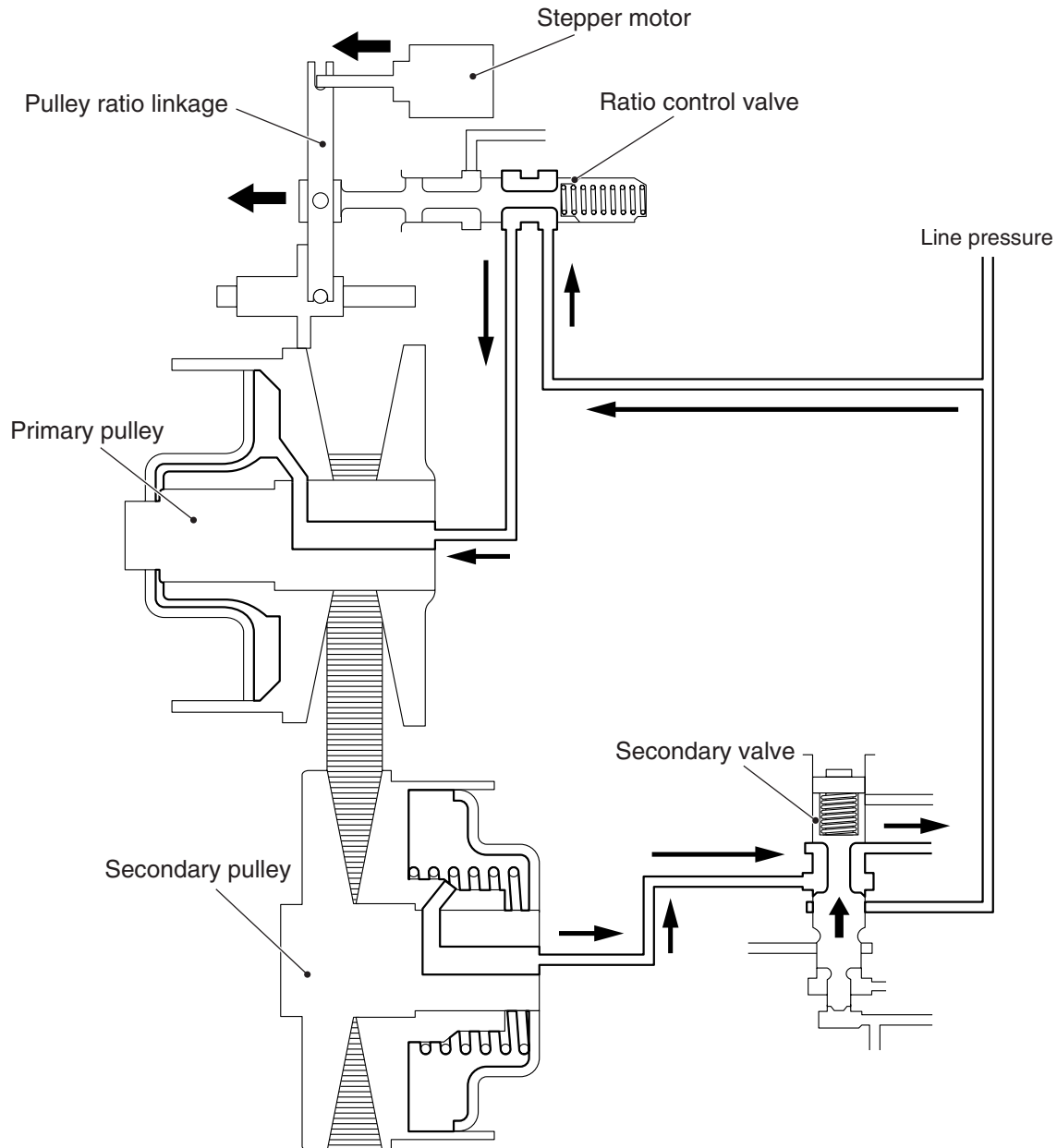

AC504743AB

- The pulley ratio linkage moves to the left by the stepper motor. This moves the ratio control valve linked to the pulley ratio linkage to open the line pressure circuit, and then the line pressure is applied to the primary pulley.
- The secondary valve moves upwards to drain the fluid in the secondary pulley.

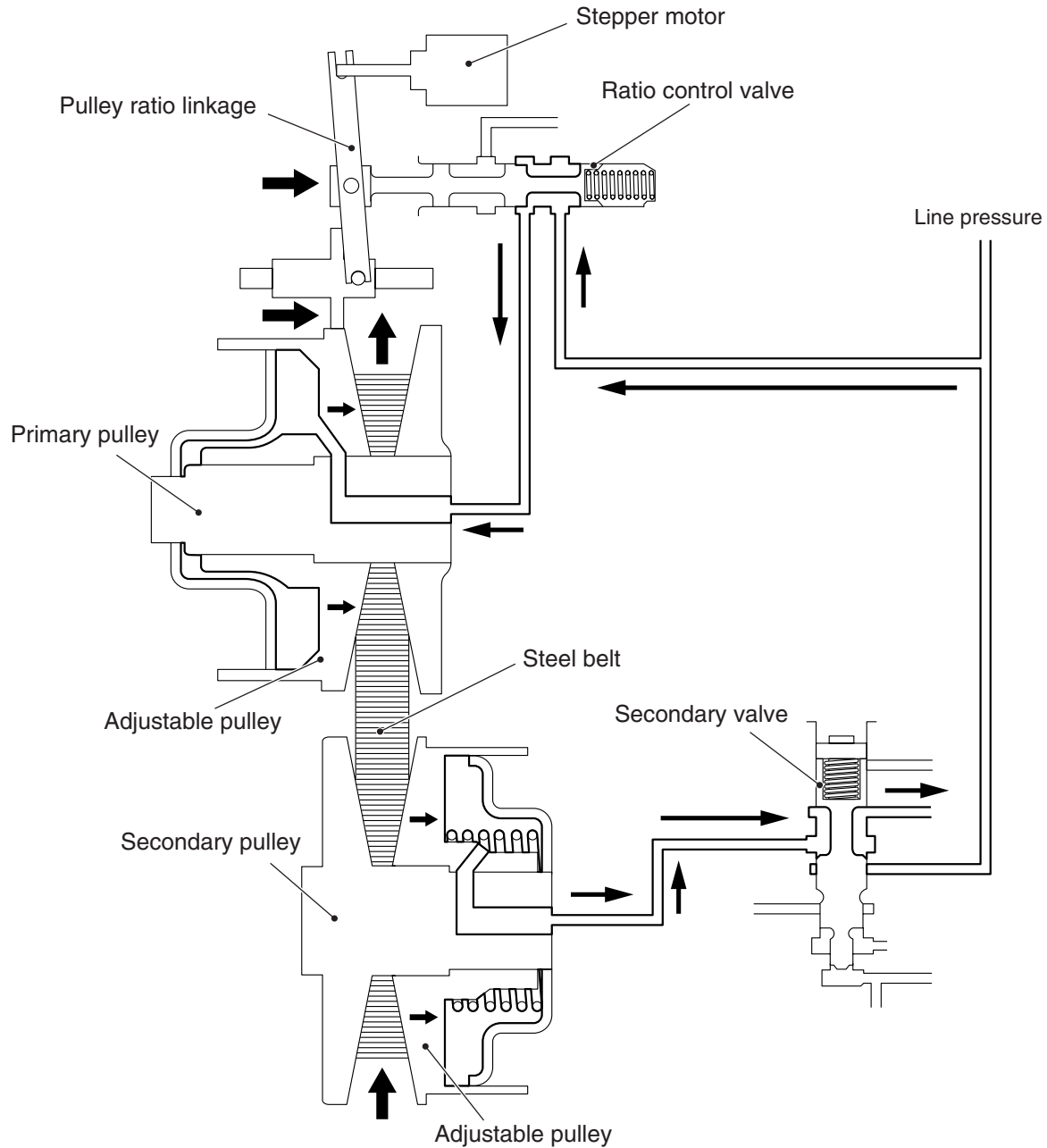

AC504744AB

- The line pressure applied to the primary pulley moves the movable pulley to the right, pressing the steel belt outwards to expand.
- When the movable pulley of the primary pulley moves to the right, the ratio control valve starts moving to the right via the pulley ratio linkage linked to the movable pulley.
- The steel belt is pulled toward the primary pulley side to move the movable pulley of the secondary pulley to the right.

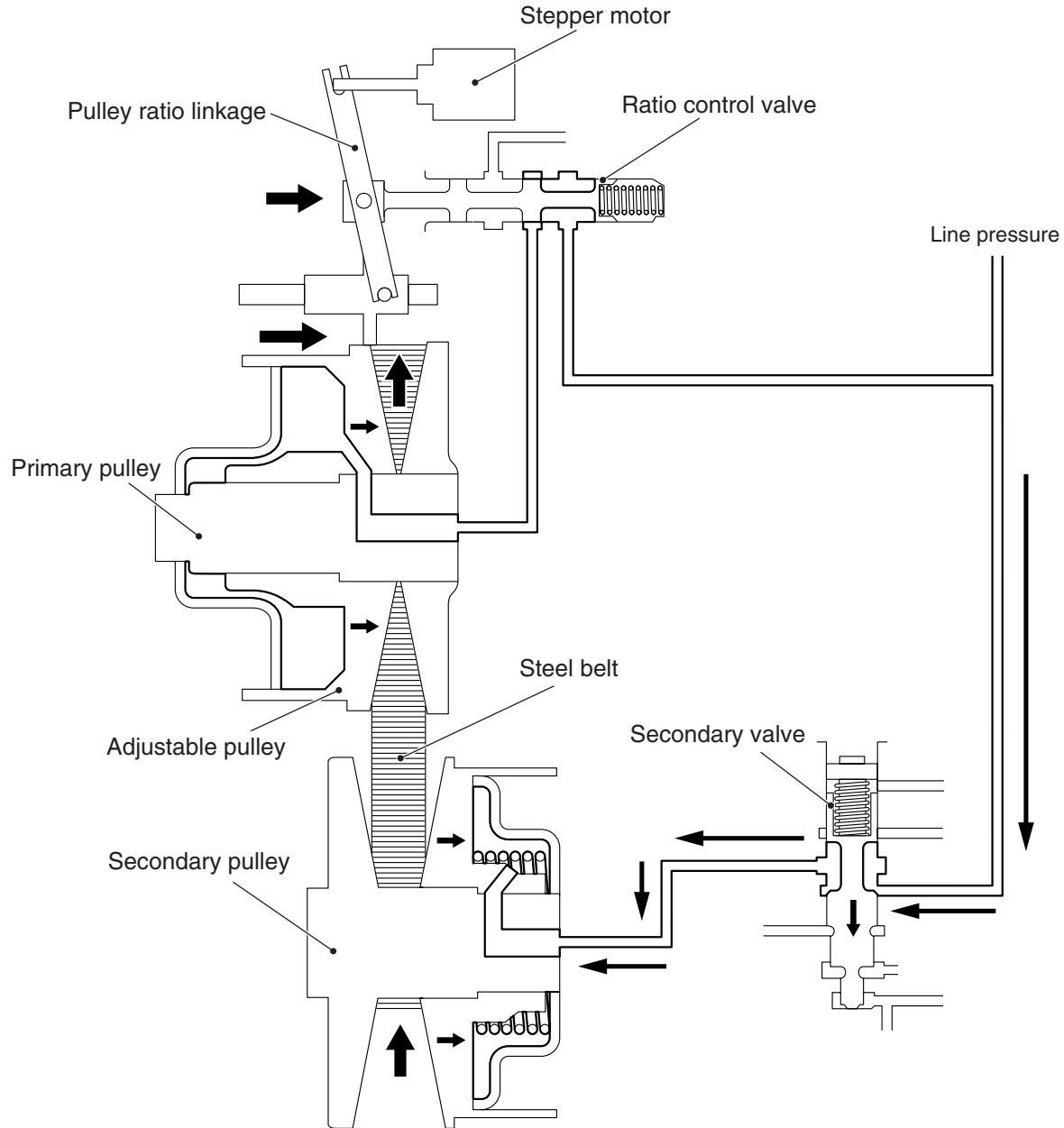

AC504745 AB

- When the movable pulley of the secondary pulley moves to the right, the ratio control valve also moves to the right to close the line pressure circuit. This completes the shift change process.
- The secondary valve moves downwards to apply the line pressure to the secondary pulley, clamping the steel belt.

SHIFTING FROM HIGH TO LOW

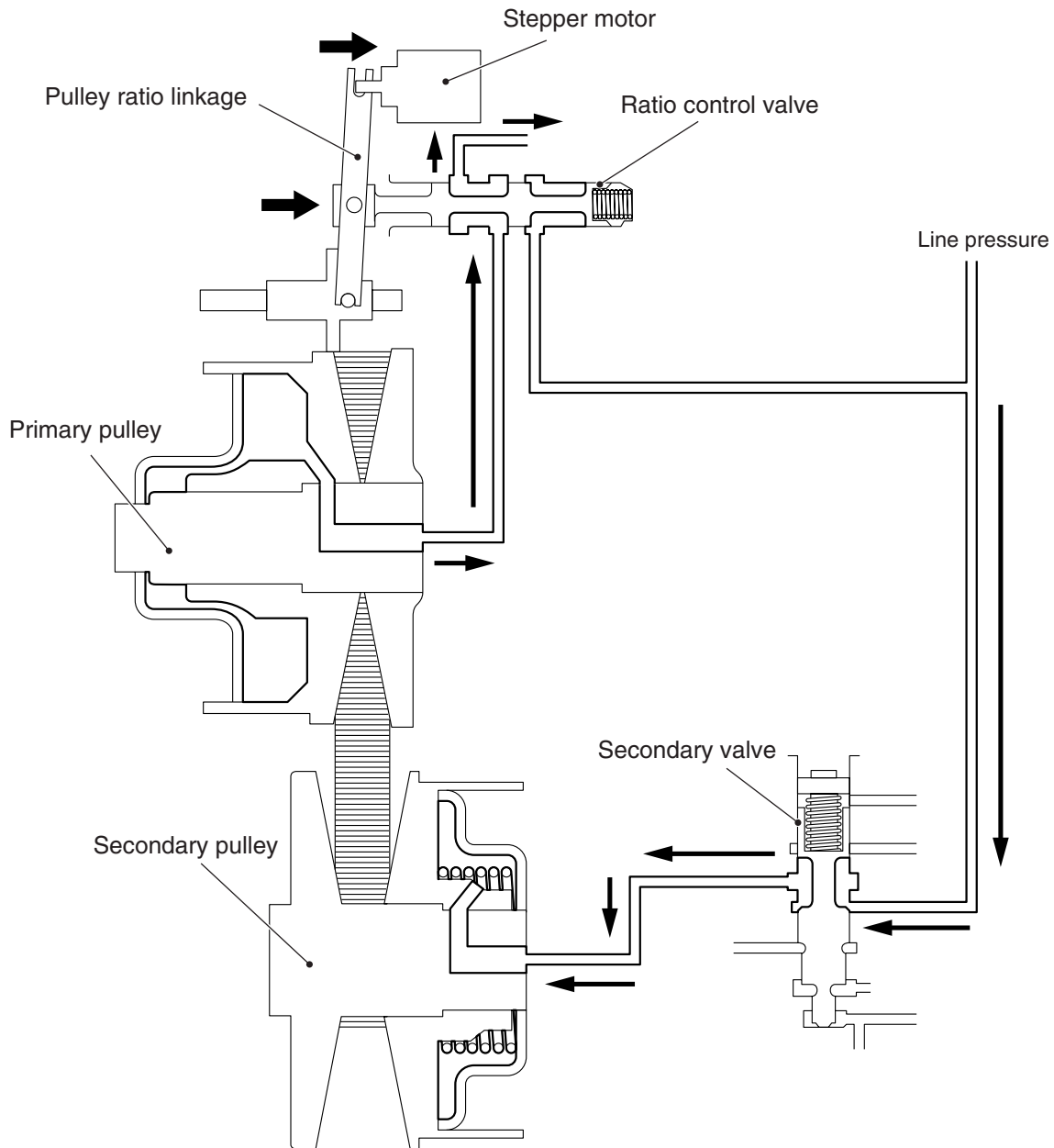

- The pulley ratio linkage moves to the right by the stepper motor. This moves the ratio control valve linked to the pulley ratio linkage to drain the fluid in the primary pulley.

- The line pressure is applied to the secondary pulley because the secondary valve has moved downwards.

AC504746 AB

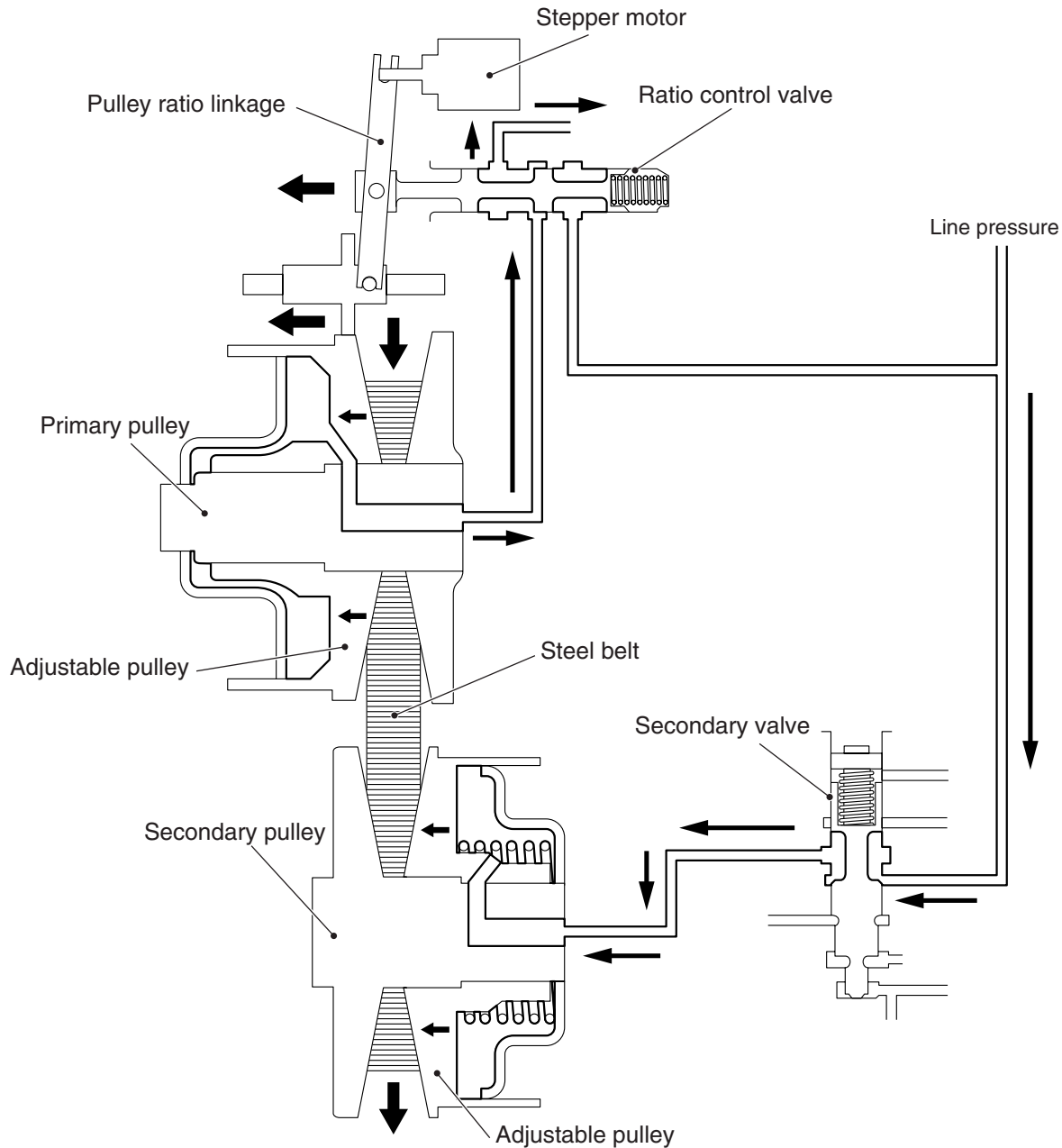

AC504747 AB

- The line pressure applied to the secondary pulley moves the movable pulley to the left, pressing the steel belt outwards to expand.
- The steel belt is pulled toward the secondary pulley side to move the movable pulley of the primary pulley to the left.
- When the movable pulley of the primary pulley moves to the left, the ratio control valve starts moving to the left via the pulley ratio linkage linked to the movable pulley.

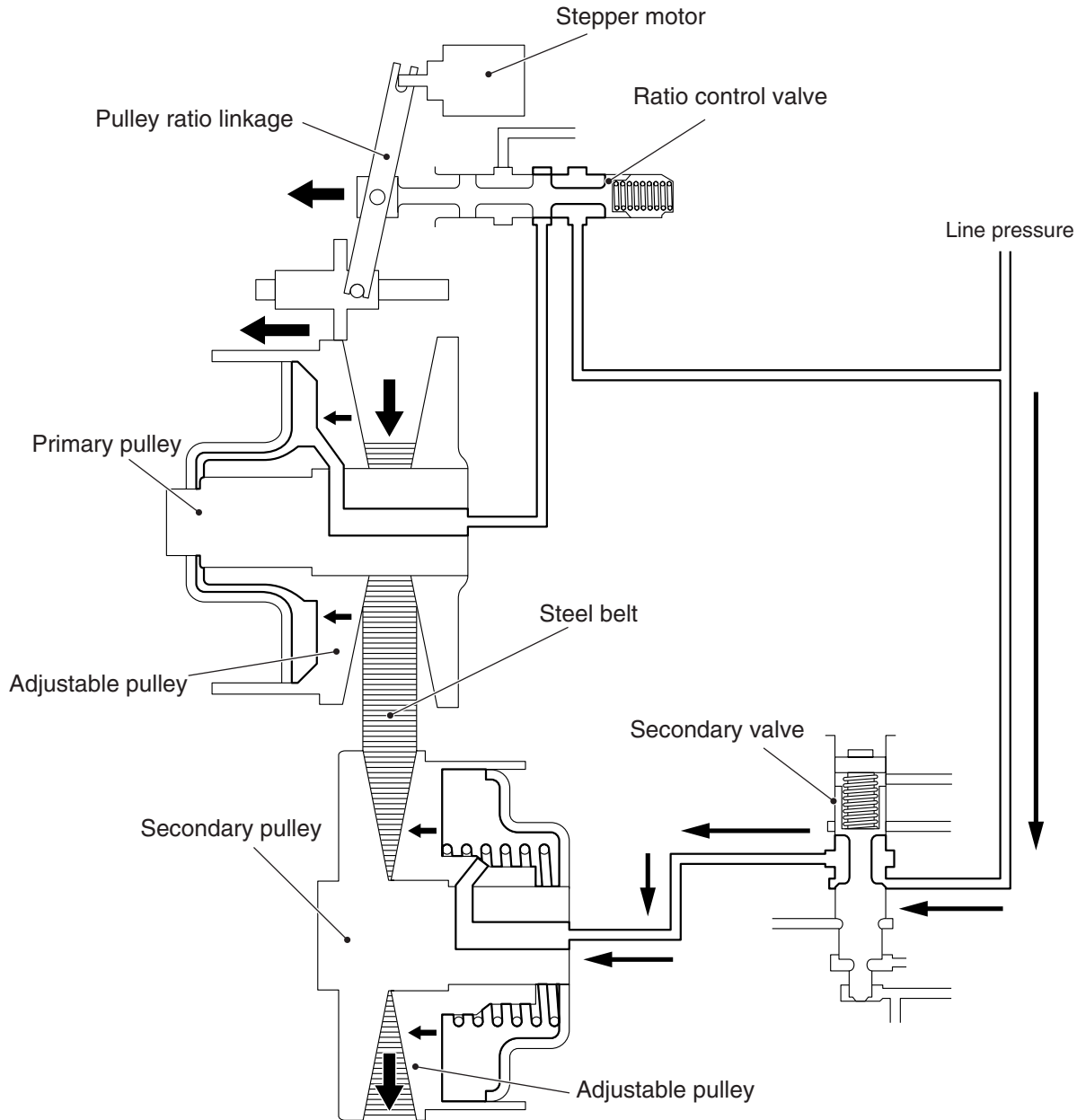

AC504748AB

- When the movable pulley of the secondary pulley moves to the left to press the steel belt outwards to expand, the movable pulley of the primary pulley moves further to the left accordingly.
- When the movable pulley of the primary pulley moves to the left, the ratio control valve also moves to the left to close the drain circuit. This completes the shift change process.

ELECTRONIC CONTROL SYSTEM

CONTROL DESCRIPTION

M2231005000099

The electronic control mechanism is comprised of various sensors, actuators, and CVT-ECU which controls them.

CVT-ECU calculates the vehicle status from various sensor information and drives each solenoid valve to perform the following controls:

- Shift control (INVECS-III, sport mode)
- Line pressure control
- Control between N (P) and D (R)
- Direct control

- Engine and CVT integrated control (CAN communication)
- Self-diagnosis function

CONTROL SYSTEM DIAGRAM

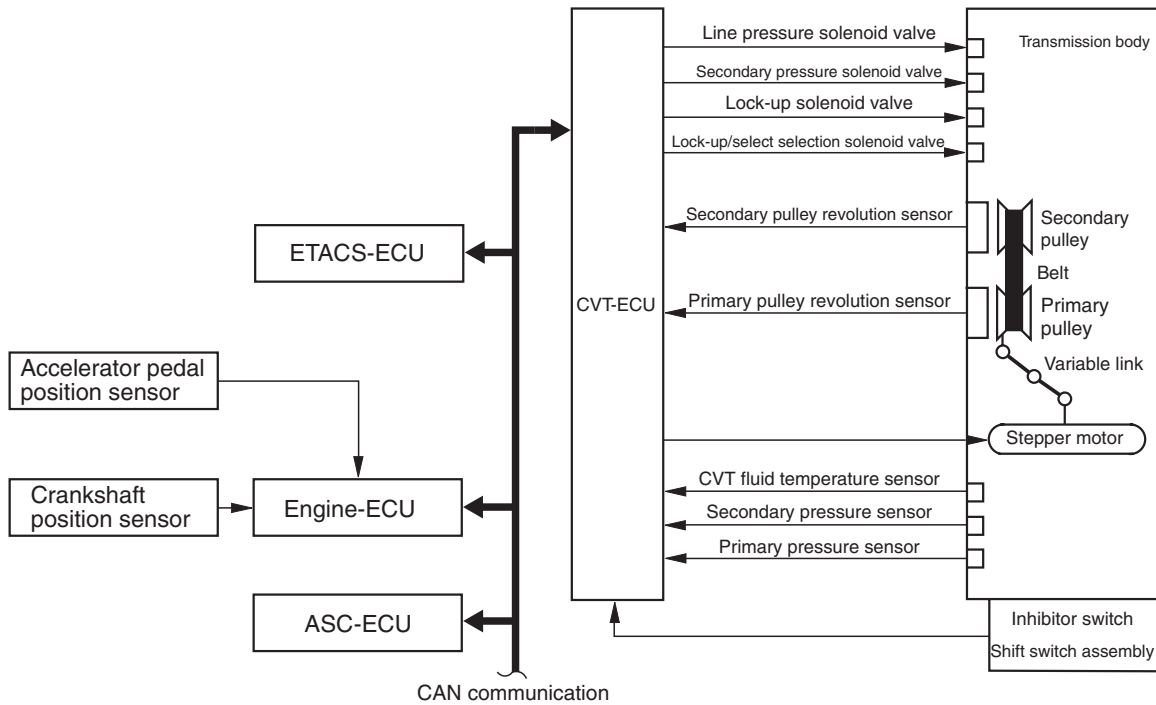

AC504728 AB

SENSOR LIST

Name	Function
SENSOR	Primary pulley rotation sensor
	Outputs the primary pulley (input shaft) speed as a pulse signal to CVT-ECU.
	Secondary pulley rotation sensor
	Outputs the secondary pulley (output shaft) speed as a pulse signal to CVT-ECU. The pulse signal is converted to the vehicle speed by CVT-ECU.
	CVT fluid temperature sensor
	Detects the CVT fluid temperature.
	Primary pressure sensor
	Detects the pressure applied to the primary pulley.
	Secondary pressure sensor
	Detects the pressure applied to the secondary pulley.
	Inhibitor switch
	Detects the selector lever position by the contact-type switch.
	Shift switch assembly
	Detects the request in the sport mode by the contact-type switch at the selector lever.
	Paddle shift switch
	Detects the operation status of the paddle shift switch.

SHIFT CONTROL

M2231001400040

To select the gear ratio which can provide the driving force corresponding to the driver's intention and vehicle conditions, CVT-ECU selects the optimal gear ratio and determines the shift strategy to obtain it by detecting the vehicle driving conditions such as the

vehicle speed, accelerator angle. Then, it outputs the command to the stepper motor, controls in/out flow of the line pressure to/from the primary pulley, positions the movable pulley of the primary pulley, and controls the gear ratio.

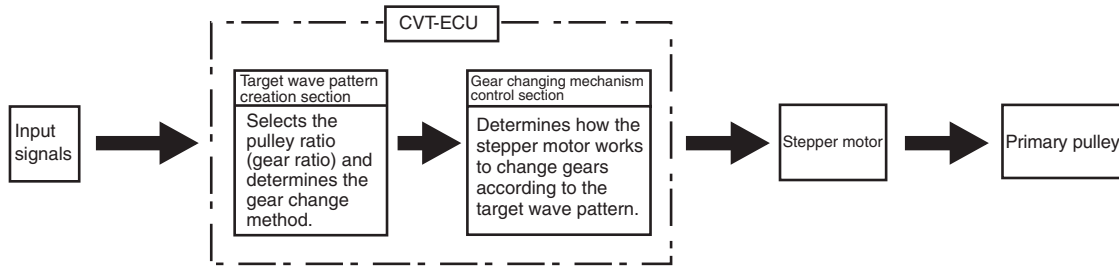

AC504721AB

RATIO PATTERN

<D RANGE>

The gear ratio is controlled based on the ratio pattern for each predetermined range to achieve the optimal gear ratio.

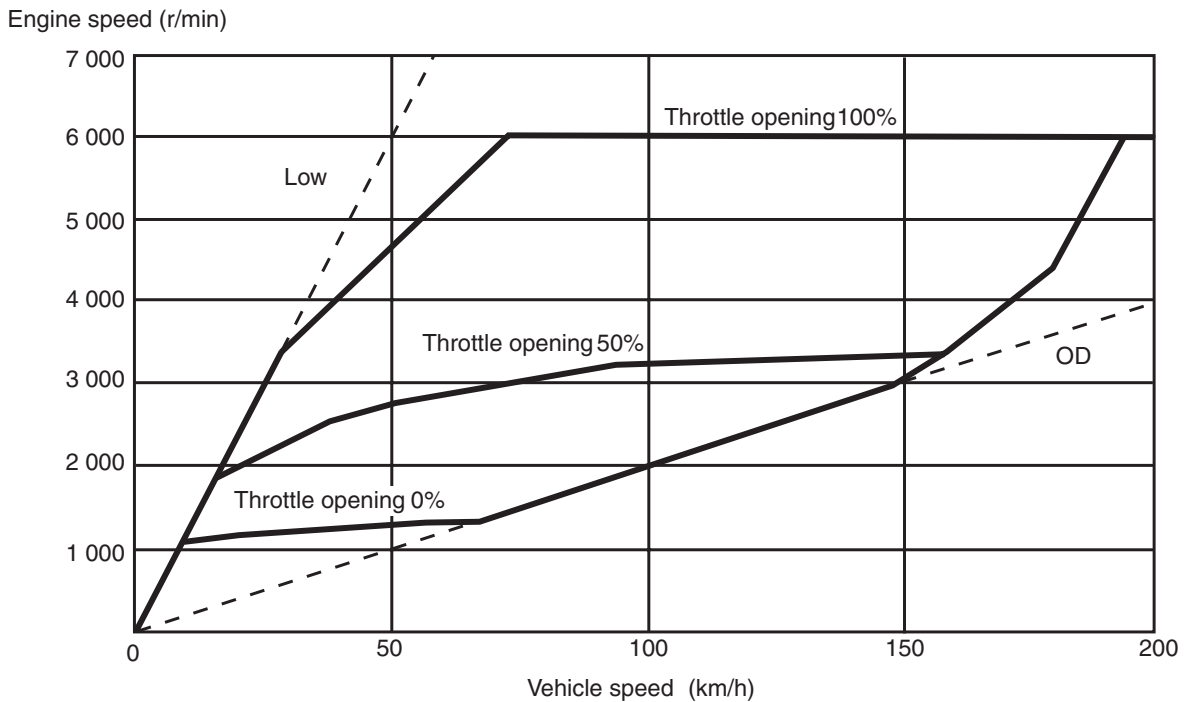

AC506956AB

The shift change is performed in the entire shift range from the lowest to the highest gear ratio.

<Ds RANGE>

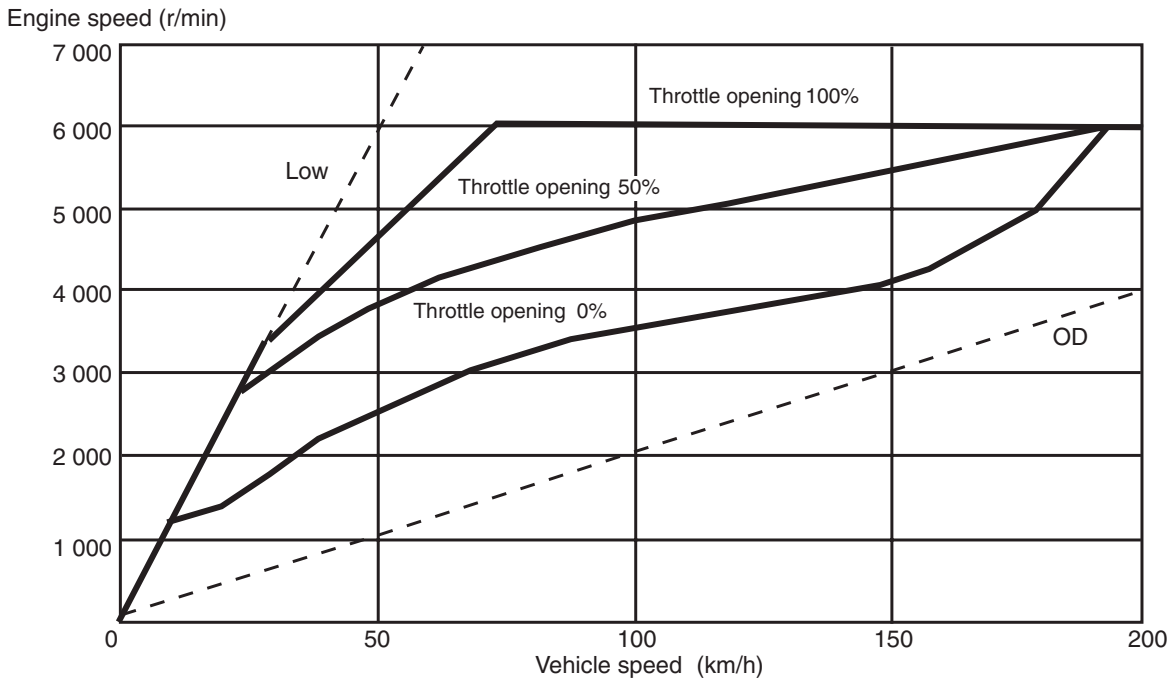

AC506957AB

By limiting the shift range to the area around the lowest gear ratio, the powerful driving force and engine brake is secured.

<SPORT MODE>

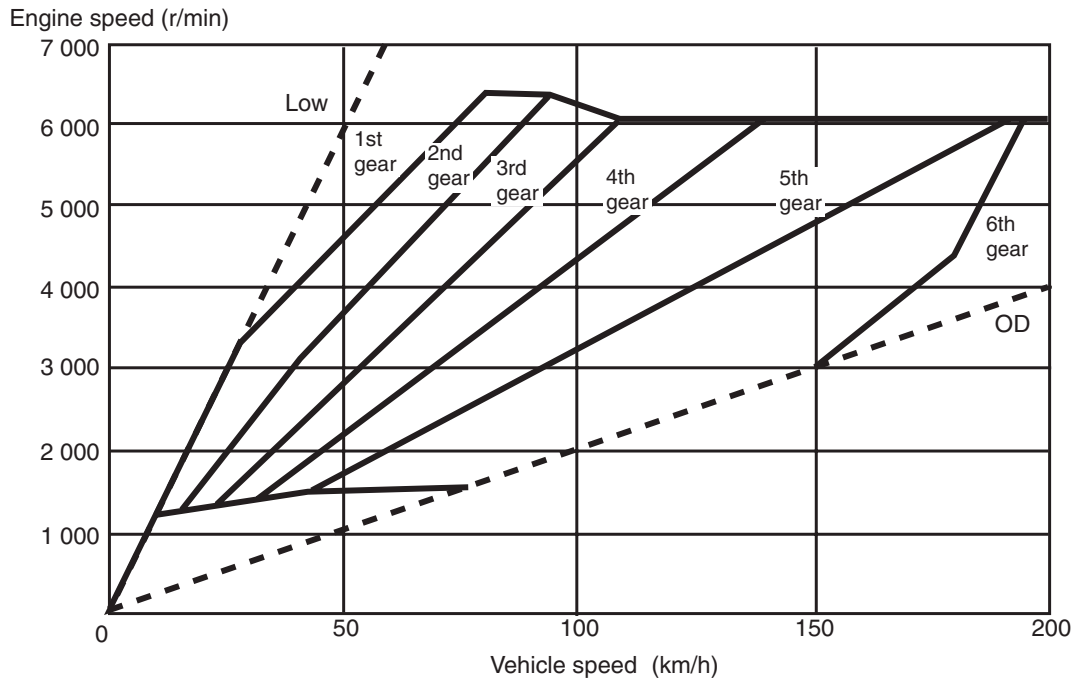

AC506955AB

When the sport mode is switched ON with the selector lever or paddle shift, the fixed shifting line is determined. The upshift/downshift operation enables to shift in steps according to the predetermined shifting line, providing MT-like shifting. The 6-speed transmission which is suitable for sporty driving is adopted.

INVECS-III CONTROL

INVECS-III for CVT fitted on COLT and LANCER has also been adopted to ensure the control suitable for OUTLANDER.

LINE PRESSURE CONTROL

M2231001300032

The high-precision line pressure control and secondary pressure control have reduced the friction for better fuel economy.

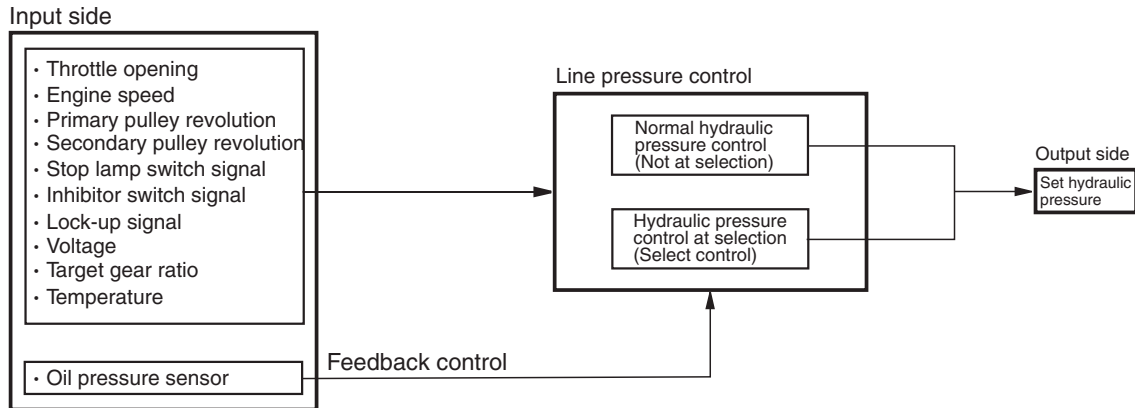

AC504722 AB

NORMAL HYDRAULIC CONTROL

The optimal line pressure and secondary pressure are determined by the accelerator angle, engine speed, primary pulley (input) speed, secondary pulley (output) speed, stop lamp switch signal, inhibitor switch signal, lock-up signal, voltage, target gear ratio, fluid temperature, and oil pressure, depending on the driving conditions.

SECONDARY PRESSURE FEEDBACK CONTROL

In the normal hydraulic control or select hydraulic control, the more precise secondary pressure has been set by detecting the secondary pressure with an oil pressure sensor, and by performing the feedback control.

DIRECT CONTROL (DAMPER CLUTCH CONTROL)

M2231007000051

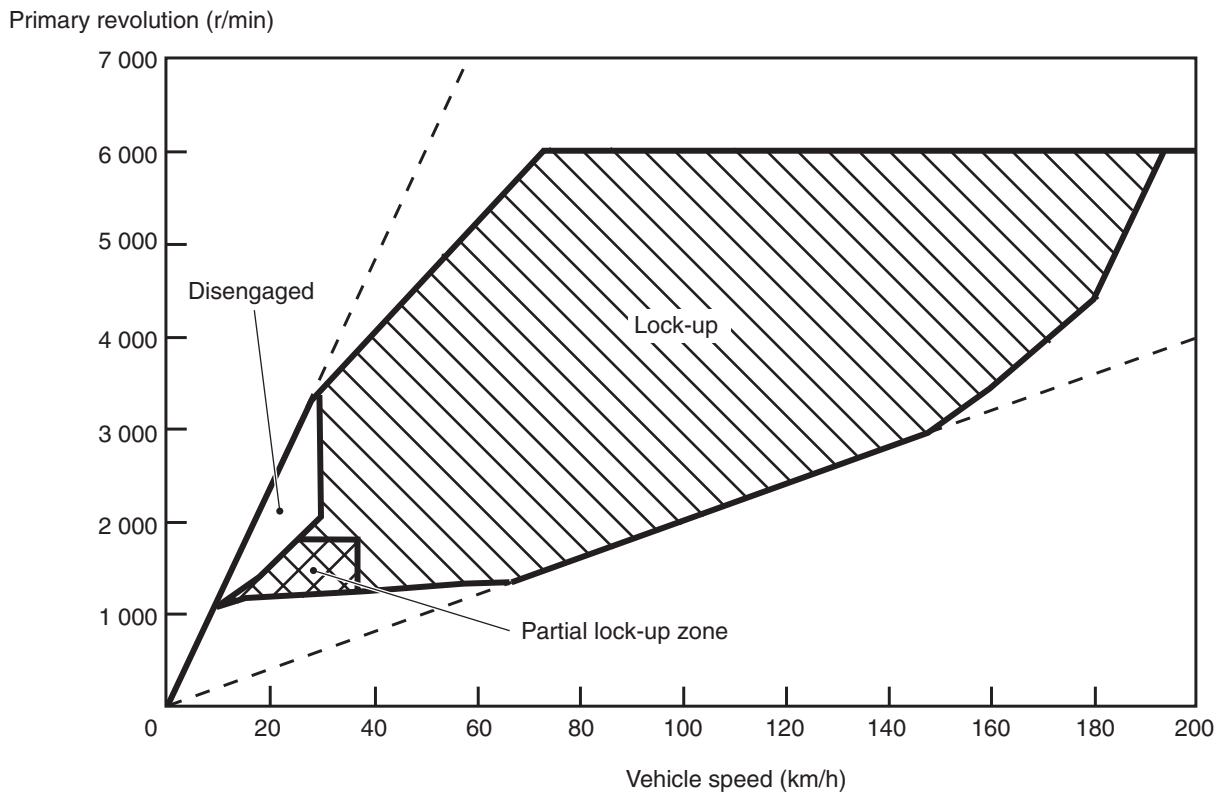

AC507421AB

By carefully controlling the direct operating pressure depending on the driving conditions, the shock-free direct operation from low speed has been achieved.

CONTROL BETWEEN N (P) AND D (R)

M2231001500036

When operation between N (P) and D (R) ranges is performed, the optimal operating pressure is determined by the accelerator angle, engine speed, and secondary pulley (output) speed to reduce the shock caused by selecting.

CONTROLLER AREA NETWORK (CAN) COMMUNICATION

M2231017000052

The information transmission between each control unit has been ensured via the CAN communication. For further details on CAN, refer to GROUP 54C, CAN P.54C-2 .

ENGINE AND CVT INTEGRATED CONTROL (CAN COMMUNICATION CONTROL)

- To control for better shift feeling and preventing the engine speed from dropping, the engine ECU and CVT-ECU communicate each other to exchange the engine output control signal to provide the real-time linkage control depending on the vehicle driving conditions.
- CVT-ECU transmits information such as the rapid deceleration signal, lock-up in progress signal, torque down request signal to the engine ECU, and also receives information such as the torque down permission/prohibition signal, lock-up permission/prohibition signal, accelerator angle.

SELF-DIAGNOSIS FUNCTION

M2231001600033

DIAGNOSTIC FUNCTION

CVT-ECU is equipped with the diagnostic function to monitor the input signals from each sensor and output signals from the actuators. If abnormality occurs in the signal system, the diagnostic function memorises the abnormal symptoms and outputs a diagnosis code via M.U.T.-III.

FAIL-SAFE FUNCTION

If abnormality occurs in signals from various sensors, switches, or solenoids, this function allows controlling them with the minimum adverse effect to the driving performance. The following shows the fail-safe controls when an abnormal signal is input to CVT-ECU from each sensor.

Item	Control content
Secondary pulley rotation sensor	Performs the shift control depending on the accelerator angle. Also, prohibits the sport mode and controls as the D range.
Primary pulley rotation sensor	Performs the shift control depending on the accelerator angle and secondary pulley rotation (vehicle speed). Also, prohibits the sport mode and controls as the D range.
Inhibitor switch	Controls as the D range.
CVT fluid temperature sensor	Controls using the fixed value for the fail-safe function.
Secondary pressure sensor	Stops the secondary pressure feedback control and controls the line pressure using the fixed value for the fail-safe function. Also, suppresses the engine torque.
Primary pressure sensor	Stops the primary pressure feedback control and controls the line pressure using the fixed value for the fail-safe function. Also, suppresses the engine torque.
Line pressure solenoid valve	Switches the line pressure solenoid valve OFF to achieve the maximum line pressure.
Secondary pressure solenoid valve	Switches the secondary pressure solenoid valve OFF to achieve the maximum secondary pressure.
Lock-up solenoid valve	Switches the lock-up solenoid valve OFF to release lock-up.
Stepper motor	Switches all the coils A to D of the stepper motor OFF to retain the gear ratio just before the abnormality occurs.
Lock-up/select switching solenoid valve	Switches the lock-up/select switching solenoid valve OFF to release lock-up.
Back-up power supply	If the control memory back-up power supply from the battery is not supplied to CVT-ECU, limits the engine torque to protect the transmission main body. After the normal power is supplied, turning the key switch from OFF to ON once resumes the normal status.
Paddle shift switch	Prohibits the paddle shift operation.
Shift switch assembly	Prohibits the sport mode operation.

TRANSMISSION CONTROL

GENERAL INFORMATION

M2232000100577

The selector lever with the gate-type has been adopted. For vehicles with some models, the paddle shift has been equipped around the steering wheel to achieve "Fun to Drive." The selector lever has the following features:

- The shift gate configuration and the operating power at each shift position have been properly tuned, ensuring the firm and smooth operation feel.
- The sport mode (6-speed) has been installed to allow the driver to shift manually according to his/her intention.

- The shift knob painted in metallic silver with a high-grade appearance has been adopted, and for higher level specifications, the genuine-leather shift knob has been provided.
- The main components have been made of resin to reduce weight and number of components.
- The electrical control-type shift lock mechanism with the solenoid to facilitate the tuning work in assembly.
- The cable control-type key interlock mechanism which is field proven has been adopted.

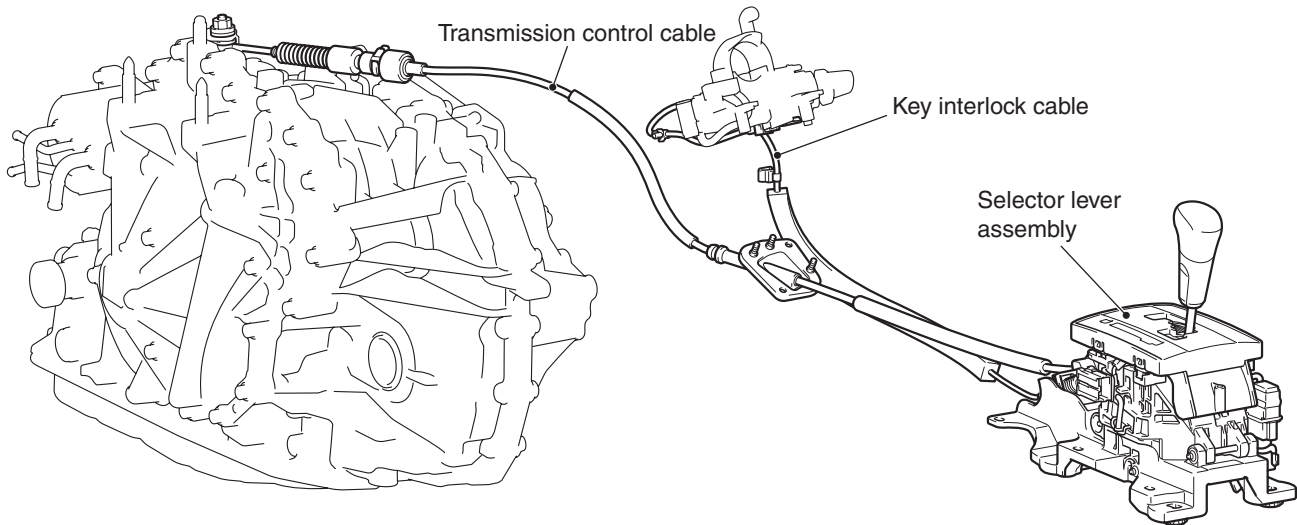
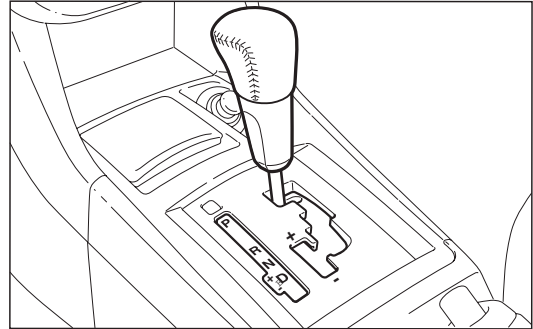

SELECTOR LEVER ASSEMBLY

M2232002000253

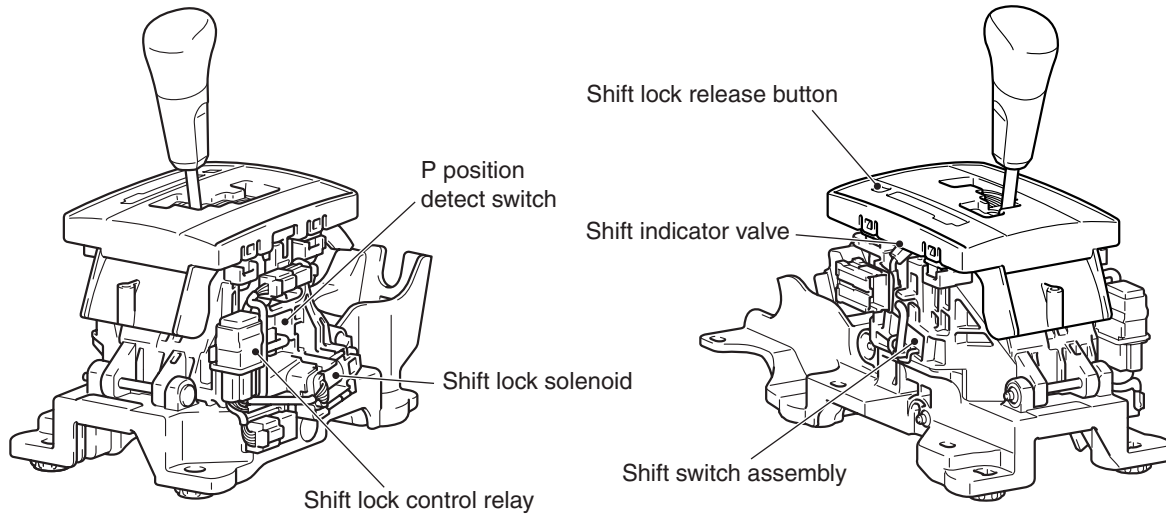

AC610078AC

The electrical control-type shift lock (the shift lever is locked in the "P" position if the brake pedal is not depressed) mechanism has been adopted for the selector lever assembly. The functions of each switch are as follows:

Name	Function
Shift lock release button	If the shift lock system has failed, remove the cover and press the shift lock release button to release the shift lock forcibly (mechanically).
Shift indicator bulb	Illuminates the present selector lever position in the shift indicator.
Shift switch assembly	Detects the selector lever activation in sport mode.
Shift lock solenoid	Switches the shift lock mechanism ON/OFF.
Shift lock control relay	Switches the shift lock solenoid power supply circuit ON/OFF.
P position detection switch	Detects the "P" position.

**CVT ERRONEOUS OPERATION
PREVENTION MECHANISMS**

SHIFT LOCK MECHANISM

M2232000400073

STRUCTURE OF SHIFT LOCK SYSTEM

This system is comprised of the following components.

- Lock lever
- Shift lock solenoid
- Shift lock control relay
- P position detection switch

SHIFT LOCK CIRCUIT

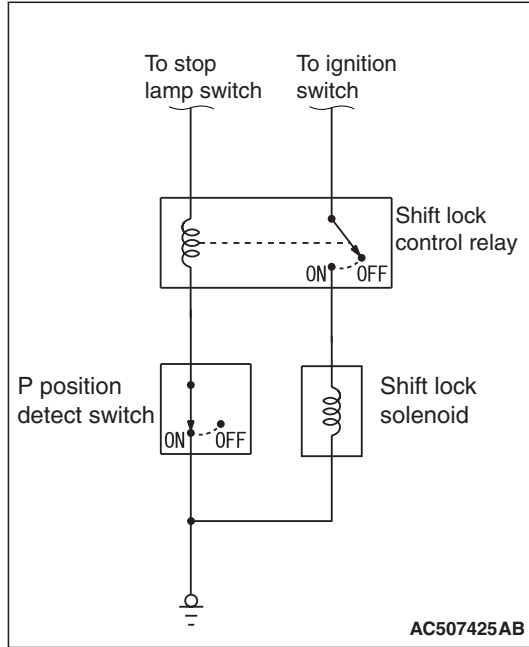

When all of the following conditions are true, the shift lock solenoid is energised, allowing the selector lever to move from the P position to another position.

- Ignition switch: ON
- P position detection switch: ON (the selector lever is in the P position)
- Stoplight switch: ON (brake pedal is depressed)

OPERATIONAL DESCRIPTION
SHIFT LOCK STATUS

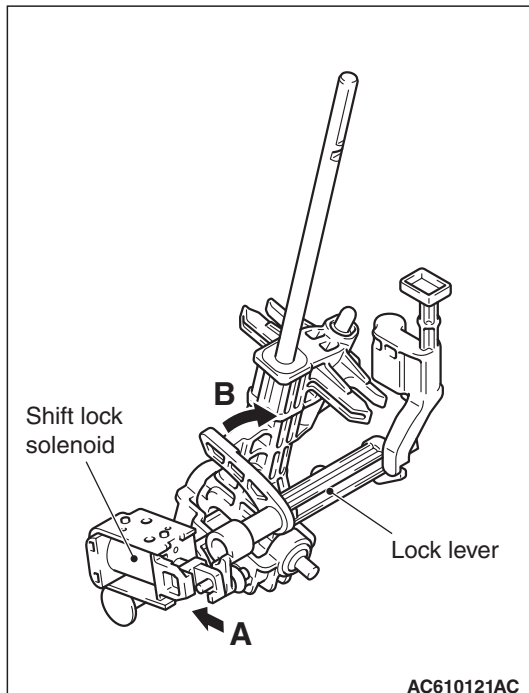

With the shift lock status, the shift lock solenoid is not energized, so when the select operation of the selector lever is attempted, no select operation is possible because the lock lever blocks the lever assembly path.

SHIFT LOCK RELEASE STATUS

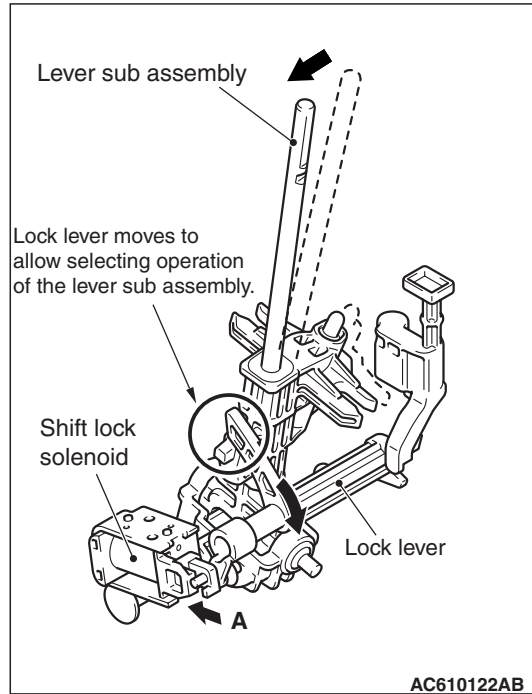

When the ignition switch is ON, the selector lever is in the P position, and the brake pedal is depressed, the shift lock solenoid is energized to move the shift lock solenoid toward the direction A shown in the figure. Then the lock lever linked to the shift lock solenoid moves as shown in the figure, and no longer blocks the lever sub assembly path when the select operation is performed, enabling the operation.

RELEASE USING THE SHIFT LOCK RELEASE BUTTON

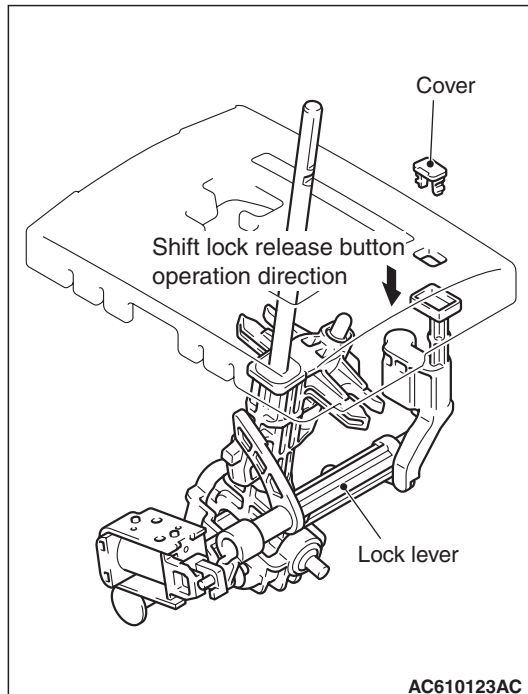

If the shift lock no longer operates properly due to a dead battery or the like, remove the cover and press the shift lock release button to enable shift operation from the P position. Pressing the shift lock release button moves the lock lever to the position shown in the figure, enabling shift operation.

KEY LOCK MECHANISM

M2232000500069

The cable-type key lock system which is field proven has been adopted.

PADDLE SHIFT

M2232000300065

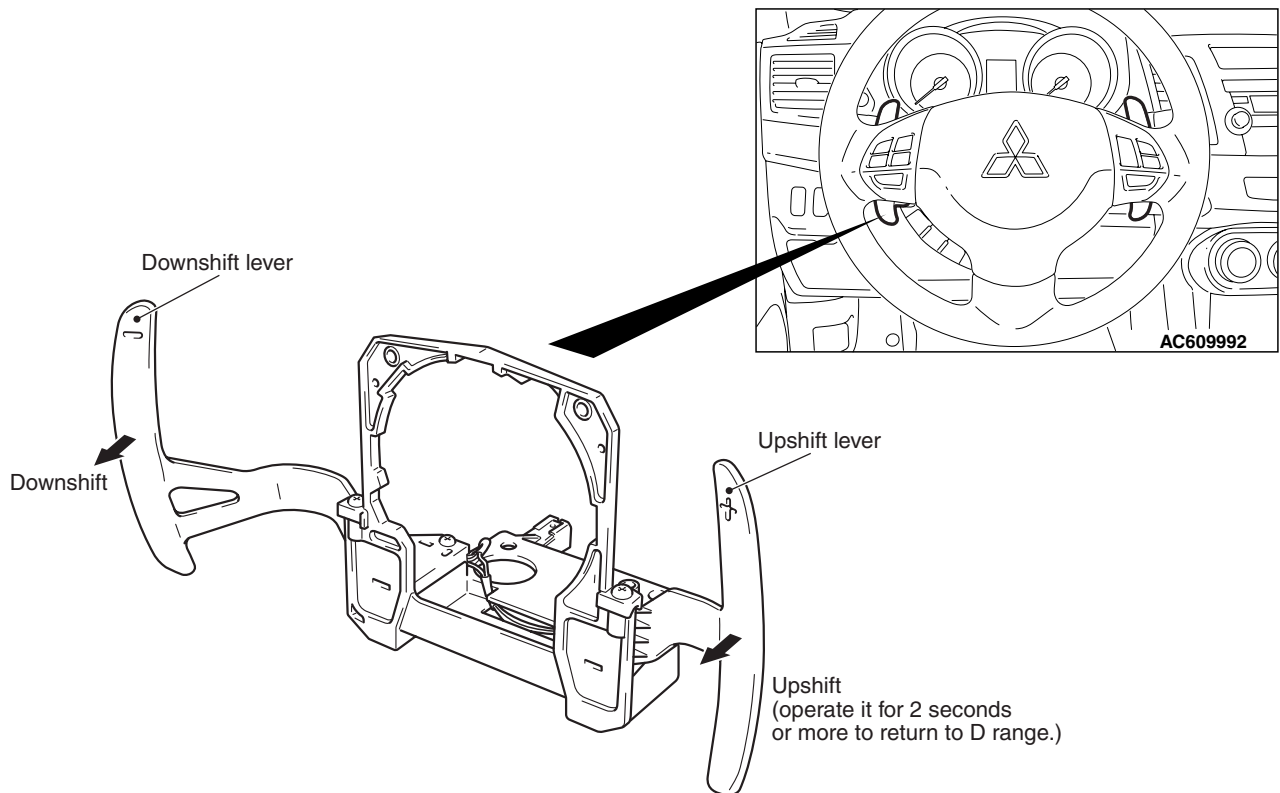

The paddle-shaped upshift/downshift lever has been fitted near the steering wheel to allow the driver to operate upshift or downshift with his/her hands kept on the steering wheel. The paddle shift has the following features:

- The lever on the right of the vehicle is for upshift and that on the left is for downshift.

AC611129AC

- As the paddle shift is fixed on the steering column to maintain the certain position regardless of the steering wheel angle, the proper operation can be performed without possibility of improper up/down position even when the steering wheel is fully turned.
- The paddle shift can perform the upshift/down-shift operation whether the selector lever is in the sport mode or automatic shifting to provide a rapid shift operation.

NOTE: When the mode is changed to the sport mode using the paddle shift during automatic gear shifting, the sport mode is cancelled under the following conditions.

- *The upshift lever is pulled for 2 seconds or more.*
- *The vehicle is stopped.*
- *No operation is carried out for 4 minutes and 25 seconds.*
- The main components have been made of magnesium alloy to achieve the considerable weight reduction and pursue a sporty impression.